

PARTS CATALOGUE FOR KH-910 KNITTING MACHINE

Parts marked "o" are new for KH-910 and not interchangeable with other model.

Le parti contrassegnate sono nuove per KH-910 e non sono intercambiabili con altri modelli.

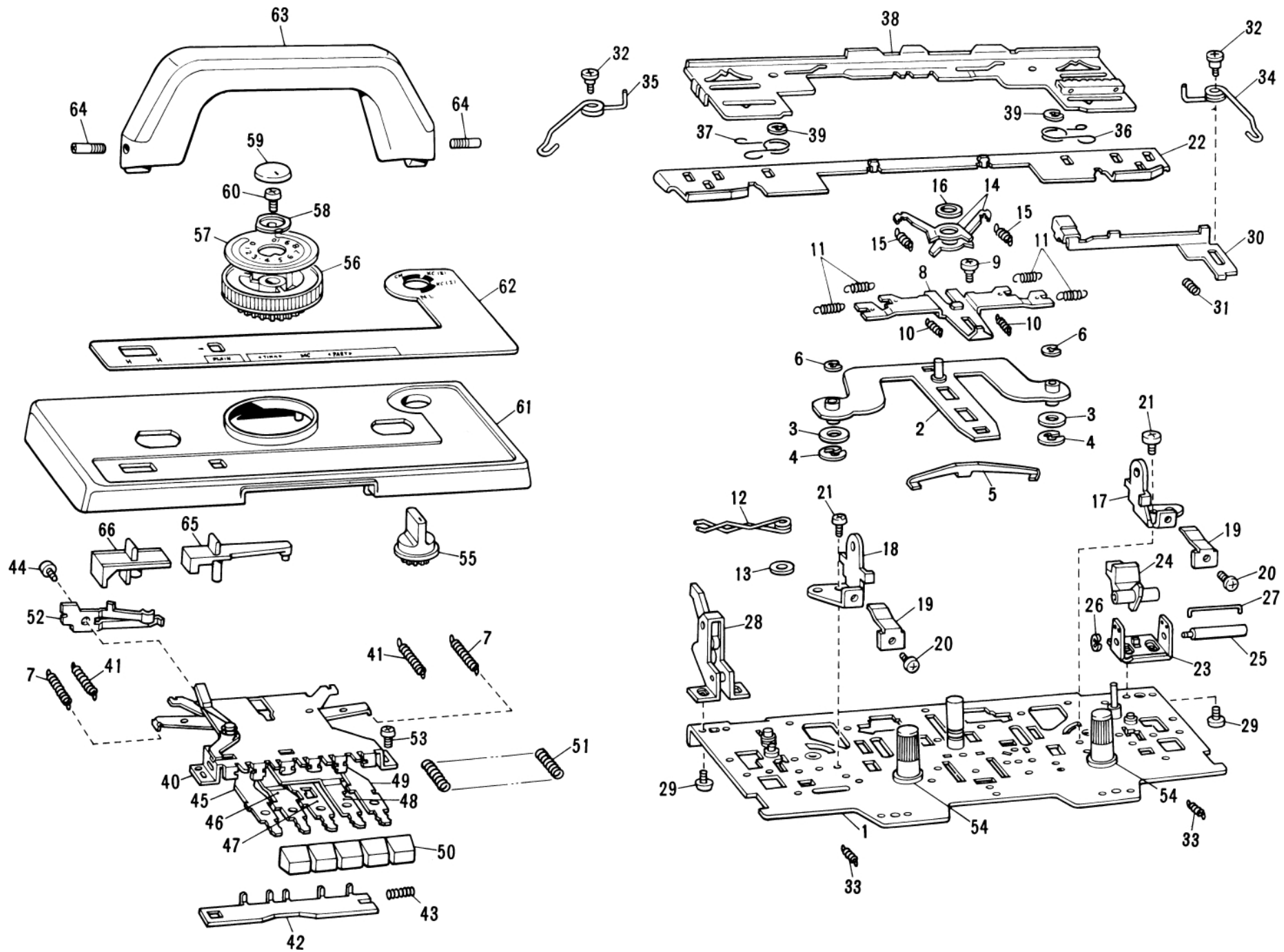

PARTS FOR CARRIAGE UPPER PART Fig: A I

PARTS FOR CARRIAGE UPPER PART

Ref. No.	Parts No.	Description	Revised	Q'ty	Ref. No.	Parts No.	Description	Revised	Q'ty
○ A I -167	410888001	K carriage complete set KH-910		1					
○ 1	410101001	Carriage plate		1					
2	409504001	Stitch cam guide plate		1					
3	405483001	Washer		2					
4	048070346	Snap ring		2					
5	409506001	Stitch cam guide plate spring		1					
6	048030346	Snap ring		2					
7	407432001	Rasing cam change spring		2					
8	407692001	Change plate		1					
9	408491001	Change plate guide collar		1					
10	407318001	Change plate spring		2					
11	407319001	MC cam spring		4					
12	407333001	H.C.L. spring		1					
13	402447003	Washer		1					
14	407341001	Tuck cam operating plate		2					
15	407342001	Tuck cam spring		2					
16	407343001	Presser ring		1					
17	409520001	Handle setting base, right		1					
18	409521001	Handle setting base, left		1					
19	409522001	Handle lock spring		2					
20	060670403	+ - Screw 3.57×4		2					
21	060680503	+ - Screw 4.37×5		2					
22	409554001	Rear plate		1					
○ 23-27	410130001	Row counter tripper		1					
○ 28	410132001	Knit-leader tripper		1					
29	060660403	+ - Screw 3.18×4		4					
○ 30	410141001	K carriage sensor magnet assembly		1					
○ 31	410145001	Shift spring for K carriage sensor		1					
○ 32	410146001	Shaft for K carriage sensor magnet		2					
○ 33	410135001	End needle selection cam spring		2					
○ 34	410136001	Needle selection change spring R		1					
○ 35	410137001	Needle selection change spring L		1					
36	409543001	Connecting plate spring, right		1					
37	409544001	Connecting plate spring, left		1					
○ 38	410138001	Upper slide plate		1					
39	048040346	Snap ring		2					
40-52	409590001	Cam button unit		1					
50	405302003	Push button		5					
52	409595001	Stitch dial notch spring		1					
53	060670403	+ - Screw 3.57×4		2					
54	409596001	Thumb nut		2					
○ 55	409597002	Change knob		1					
56	409599001	Stitch dial		1					
○ 57	409974002	Stitch dial indicator plate		1					
58	406283001	Stitch dial presser		1					
○ 59	409601002	Stitch dial cap		1					
60	060660603	+ - Screw 3.18×6		1					
○ 61-62	410809001	K carriage cover assembly KH-910		1					
○ 62	410810001	Carriage cover decoration plate KH-910		1					
63	409605001	K carriage handle		1					
64	409608001	Screw		2					
○ 65	409609002	Plain lever knob		1					
○ 66	409610002	H.C.L. knob		1					

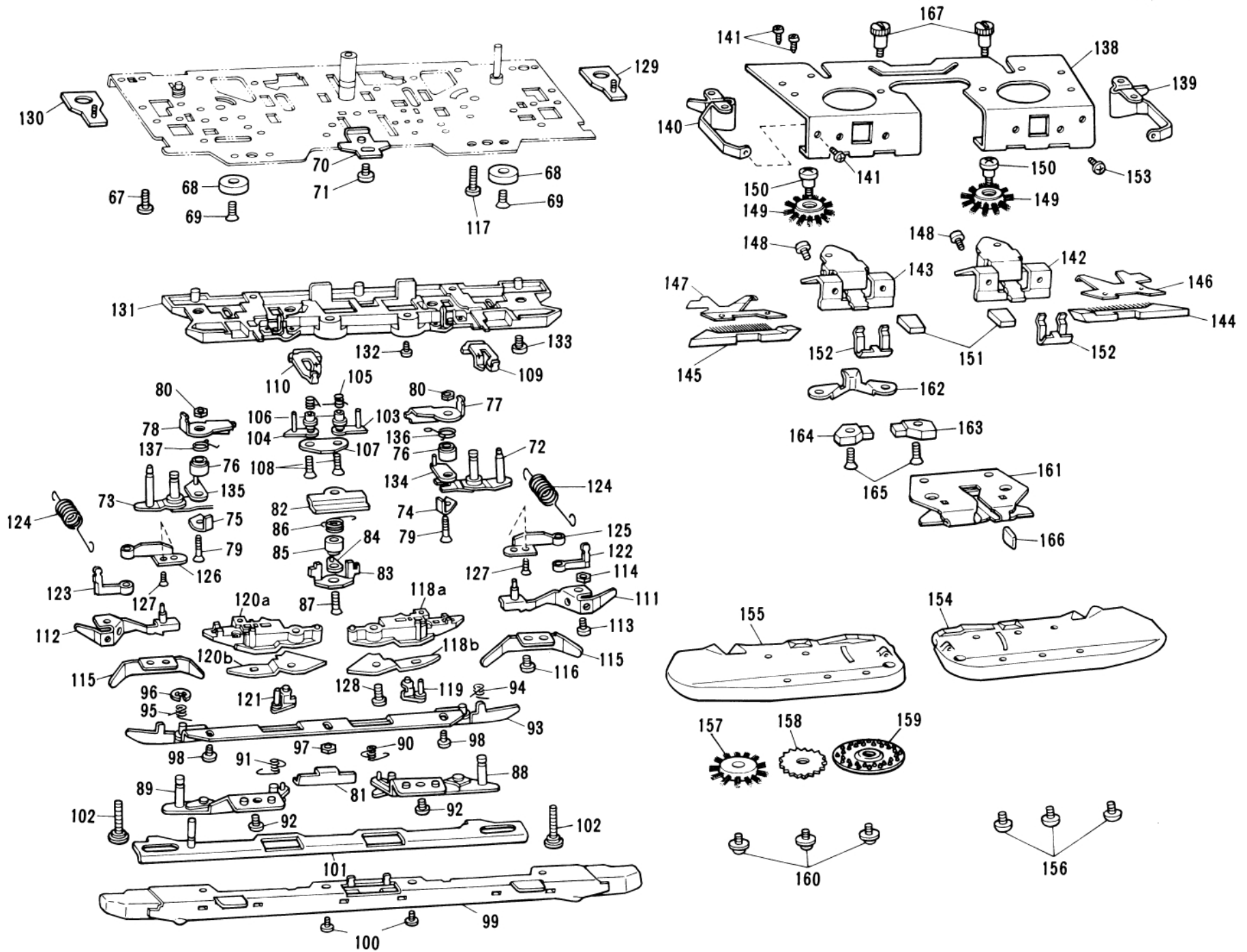

PARTS FOR CARRIAGE LOWER PART

Ref. No.	Parts No.	Description	Revised	Q'ty	Ref. No.	Parts No.	Description	Revised	Q'ty
A II - 67	037351615	Tapping screw		2	○ A II -123	410884001	Valve cam F, left		1
68	407285000	Carriage magnet 16		2	○ 124	410129001	Valve cam F, spring		2
69	408773001	Flat head screw 3.18×9		2	125	409537001	Guide cam G, right		1
70	407289001	Stripe adjuster plate		1	126	409538001	Guide cam G, left		1
71	060679303	+ - Screw 3.57×3.5		1	127	410030001	Flat head screw 2.38×14		2
○ 72	410094001	Stitch cam assembly, right		1	128	060661003	+ - Screw 3.18×10		2
○ 73	410097001	Stitch cam assembly, left		1	○ 129	410123001	Connecting plate, right		1
74	407296001	Sub stitch cam, right		1	○ 130	410125001	Connecting plate, left		1
75	407297001	Sub stitch cam, left		1	○ 131	410127001	Rear foot		1
76	407298001	Sub stitch cam shaft		2	132	060660403	+ - Screw 3.18×4		4
77	407313001	MC cam, right		1	133	409494001	Screw 3.57		2
78	407314001	MC cam, left		1	○ 134	410488001	Valve cam D, right		1
79	407312001	Screw		2	○ 135	410489001	Valve cam D, left		1
80	021660406	Nut		2	○ 136	410490001	Valve cam D spring right		1
81	408465001	Slide cam		1	○ 137	410491001	Valve cam D spring left		1
82	408466001	Slide cam guide		1	○ 138-167	411008001	Sinker plate complete set		1
83	407356001	Guide cam C		1	○ 138-160	411009001	Sinker plate assembly without feeder		1
84	407635001	Valve cam C		1	138	409979001	Sinker plate arm		1
85	408467001	Shaft for guide cam C		1	139	407427000	Weaving thread guide, right		1
86	407636001	Valve cam C spring		1	140	407428000	Weaving thread guide, left		1
87	408459001	Flat head screw C		1	141	409162001	Tapping screw 3V-2.6		6
88	408468001	Guide cam B, right		1	142	410026001	Weaving lever assembly, right		1
89	408471001	Guide cam B, left		1	143	410027001	Weaving lever assembly, left		1
90	408473001	Valve cam B spring, right		1	144	410003001	Latch opening brush, right		1
91	408474001	Valve cam B spring, left		1	145	410004001	Latch opening brush, left		1
92	408305002	Screw		2	146	408607000	Latch presser plate, right		1
93-96	407455001	Guide cam A assembly		1	147	408608000	Latch presser plate, left		1
93	407320001	Guide cam A		1	148	037280616	Screw		4
94	407325001	Holding cam spring, right		1	149	407437001	Weaving pattern brush		2
95	407326001	Holding cam spring, left		1	150	408316001	Stud screw for weaving pattern brush		2
96	048030346	Snap ring		2	151	409629001	Weaving lever knob		2
97	408524001	Nut		1	152	407441001	Weaving lever spring		2
98	408305002	Screw		2	153	408305001	Screw		4
99	409892001	Front foot		1	154	409614001	Sinker plate, right		1
○ 100	408305002	Screw		2	155	409618001	Sinker plate, left		1
101	407327001	Front slide plate		1	156	060660303	+ - Screw 3.18×3		6
102	408504001	Stud screw 3.18		2	157	407702001	Wheel brush		2
103	407579001	Tuck cam, right		1	158	405184002	Plastic gear		2
104	407586001	Tuck cam, left		1	○ 159	410988001	Rubber wheel		2
105	407338001	Tuck cam spring		1	160	409621001	+ - Screw 3.18		6
106	407339001	Shaft for tuck cam		2	161-165	409980001	Double yarn feeder assembly		1
107	407340001	Tuck cam plate		1	161	409981001	Yarn feeder body		1
108	407299001	Screw		2	162	409625000	Magnet holder plate		1
109	409510001	Selection cam for right end needle		1	163	407454000	Magnet, right		1
110	409513001	Selection cam for left end needle		1	164	407578000	Magnet, left		1
○ 111	410110001	Separation cam, right		1	165	002631003	Fastening screw, 2.38×10		2
○ 112	410113001	Separation cam, left		1	166	407450002	Yarn feeder knob		1
○ 113	410115001	Stud screw 3.18		2	167	409626001	Thumb screw		2
114	021660406	Nut		2					
115	409519001	Guide cam F		2					
116	062660403	+ - Screw 3.18×4		2					
117	062681203	+ - Screw 4.37×12		2					
○ 118	410116001	Needle selection cam, R	411491001	1					
○ 119	410117001	Needle selection change cam, right	411489001	1					
○ 120	410120001	Needle selection cam, left	411492001	1					
○ 121	410121001	Needle selection change cam, left	411490001	1					
○ 122	410883001	Valve cam F, right		1					

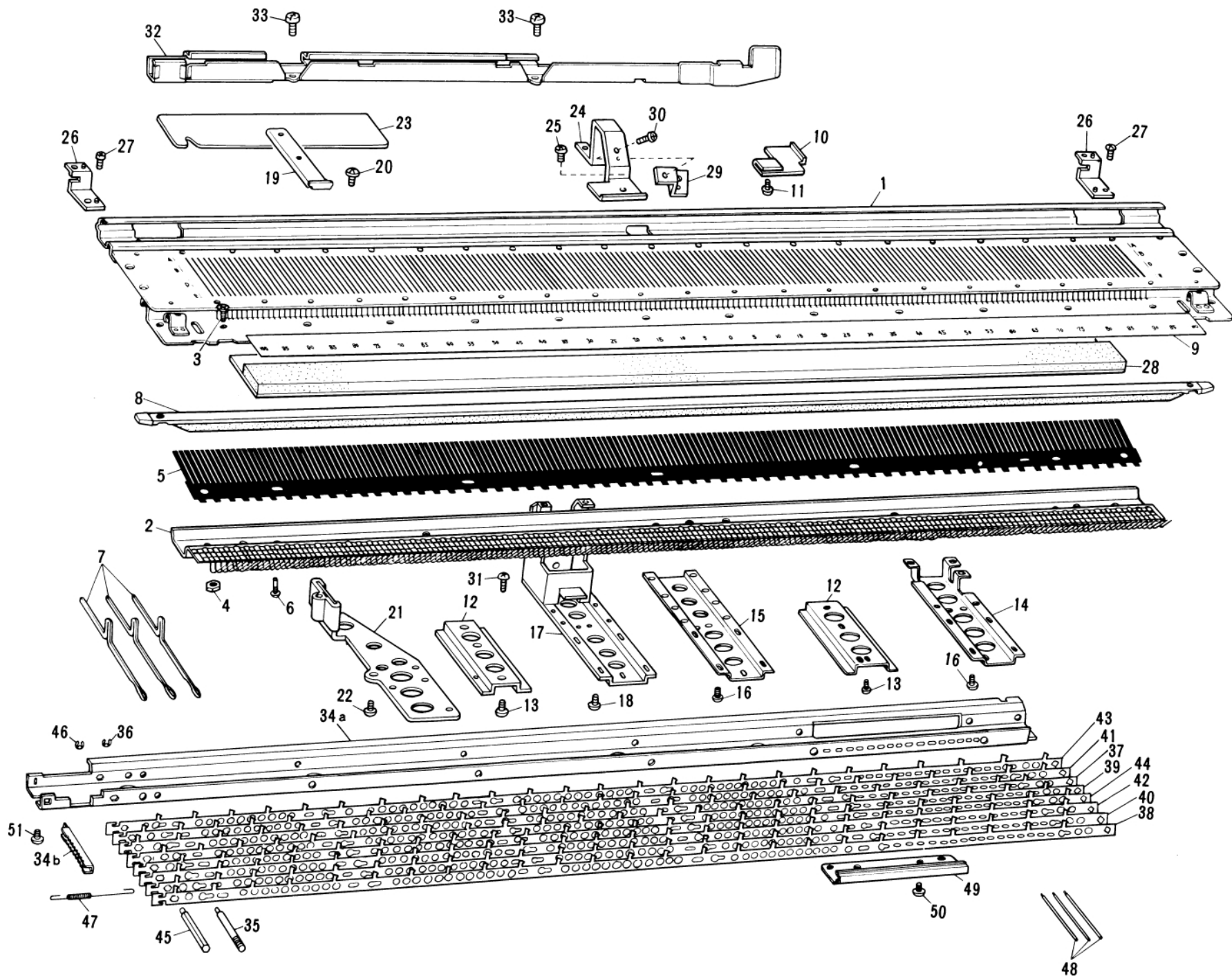

PARTS FOR NEEDLE BED

Ref. No.	Parts No.	Description	Revised	Q'ty	Ref. No.	Parts No.	Description	Revised	ty
○ B- 1	410151001	Needle bed assembly		1					
○ 2	410154001	Needle bed comb assembly		1					
○ 3	004630704	Screw		12					
○ 4	405077001	Nut		12					
○ 5	407112001	Needle retaining spring		1					
○ 6	407687001	Screw		3					
○ 7	407113001	Plain needle		200					
○ 8	409643001	Needle presser bar assembly		1					
○ 9	410157001	Needle position indicator		1					
○ 10	410156000	Timing belt cover		1					
○ 11	060660303	+ - Screw 3.18×3		1					
○ 12	407120000	Lower holder plate		2					
○ 13	409197001	Screw with washer		4					
○ 14	410159000	Stay, R		1					
○ 15	410160000	Stay center A		1					
○ 16	409197001	Screw with washer		8					
○ 17	410161001	Stay center B		1					
○ 18	409197001	Screw with washer		4					
○ 19	410170000	Carrying case reinforcing plate		1					
○ 20	410523001	+ Screw 3.18×5		1					
○ 21	410171001	Yarn tension rod stand		5					
○ 22	406397001	Screw with washer		1					
○ 23	410432000	Needle shank cover		1					
○ 24	410177000	Pattern case setting base		1					
○ 25	410523001	+ Screw 3.18×5		1					
○ 26	410175000	Position sensor board holder plate		2					
○ 27	410523001	+ Screw 3.18×5		2					
○ 28	407703000	Sponge plate		1					
○ 29	410449000	Pilot lamp-holder		1					
○ 30	060660403	+ - Screw 3.18×4		2					
○ 31	060660403	+ - Screw 3.18×4		2					
○ 32	410176001	Timing belt cover L	411014001	1					
○ 33	060660403	+ - Screw 3.18×4		2					
○ 34a-47	410188001	Needle selector plate holder assembly		1					
○ 34a-b	410189001	Needle selector plate holder		1					
○ 35	408159001	Shaft A		6					
○ 36	048025346	Snap ring		6					
○ 37	410191001	Needle selector plate 1		1					
○ 38	410192001	Needle selector plate 2		1					
○ 39	410193001	Needle selector plate 3		1					
○ 40	410194001	Needle selector plate 4		1					
○ 41	410195001	Needle selector plate 5		1					
○ 42	410196001	Needle selector plate 6		1					
○ 43	410197001	Needle selector plate 7		1					
○ 44	410198001	Needle selector plate 8		1					
○ 45	408172001	Shaft B		1					
○ 46	048025346	Snap ring		1					
○ 47	410476001	Needle selector plate spring		8					
○ 48	408098001	N.S.P. operation lever		16					
○ 49	410199001	Operation lever presser		1					
○ 50	060660403	+ - Screw 3.18×4		2					
○ 51	409197001	Screw with washer		8					

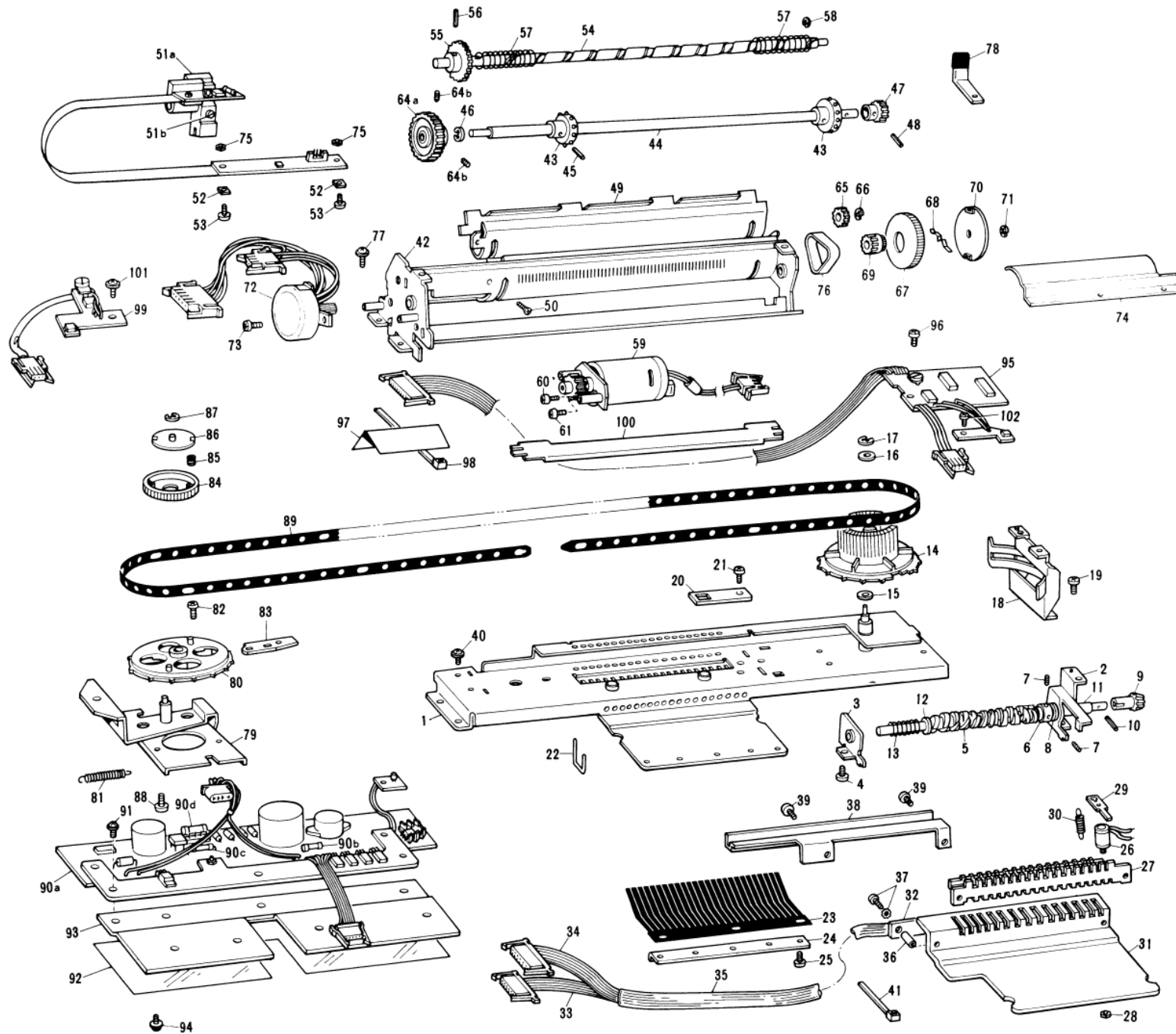

PARTS FOR NEEDLE SELECTOR UNIT Fig. C

PARTS FOR NEEDLE SELECTOR UNIT

Ref. No.	Parts No.	Description	Revised	Q'ty	Ref. No.	Parts No.	Description	Revised	Q'ty
○ C- 1-39	410201001	Rotary cam holder body assembly		1	○ C-53	002301003	+ - Screw 3×10		2
○ 1	410202001	Rotary cam holder body		1	○ 54	410272001	Spiral shaft for mark sensor		1
○ 2	410207001	Rotary cam holder right		1	○ 55	410273000	Mark sensor feeding gear Z53		1
○ 3	410210001	Rotary cam holder left		1	56	047211250	Spring pin BW2		1
○ 4	409197001	Screw with washer		2	○ 57	410274001	Buffer spring	{ 57R 412127001 57L 410274001	2
○ 5	410212001	Rotary cam		1	58	048040346	Snap ring		1
○ 6	410215001	Rotary cam adjustor collar		1	○ 59-60	410276001	DC motor & holder plate assembly		1
7	013680516	Stopper screw		2	○ 60	002260503	+ Screw 2.6×5		2
○ 8	411013001	Washer		1	○ 61	000300503	+ Screw 3×5		2
○ 9	410216000	Bevel gear Z12		1	○ 64a-b	410288001	Gear Z60 for card feeding		1
10	047201042	Spring pin AW2		1	○ 64b	015300516	Stopper screw 3		2
○ 11	410217001	Spacer 6.2×19		1	○ 65	410292000	Idle gear Z20		1
12	025060232	Washer 6		1	66	048020346	Snap ring		1
○ 13	410218001	Rotary cam presser spring		1	○ 67	410294001	Card feeding dial		1
○ 14	410219001	Rotary encoder assembly		1	○ 68	410295001	Card feeding dial notch spring		2
○ 15	410223001	Washer 6.3		1	○ 69	410296000	Gear Z16 for card feeding dial		1
16	400806004	Washer		1	○ 70	410300001	Card feeding dial cover		1
17	048025346	Snap ring		1	71	048020346	Snap ring		1
○ 18	410245001	Encoder board holderr		1	○ 72	410282001	Pulse motor assembly		1
19	409197001	Screw with washer		2	○ 73	000300503	+ Screw 3×5		2
20	408068001	Card reader guide stopper		1	○ 74	410470000	Oil protector for rotary cam		1
21	060660403	+ - Screw 3.18×4		1	75	021300106	Nut 1-3		2
○ 22	410225001	Rotary cam lever		16	○ 76	410293000	Gear cover		1
○ 23	410226001	Rotary cam lever spring		1	77	409197001	Screw with washer		3
○ 24	410227000	Cam lever spring presser plate		1	○ 78	410303001	Encoder signal cord stopper		1
25	060660403	+ - Screw 3.18×4		5	○ 79-87	410181002	Pulley assembly		1
○ 26-37	410228001	Needle selector solenoid assembly		1	○ 79	410180001	Pulley holder plate		1
○ 26	410229001	Solenoid		16	○ 80	410182002	Pulley		1
○ 27	410238001	Solenoid yoke 16		1	81	410016001	Belt tension control spring		1
28	021260106	Nut 1-2.6		16	82	410072001	Screw with washer		2
○ 29	410239001	Armature		16	83	410071000	Pulley adjusting plate		1
○ 30	410240001	Spring for armature		16	○ 84	410477001	Friction plate		1
○ 31	410241000	Heat sinker plate for solenoid		1	○ 85	410479001	Friction plate spring		4
○ 32	410327001	Solenoid board		1	○ 86	410478000	Presser for friction plate spring		1
○ 33	410402001	Solenoid cord #2		1	87	048030346	Snap ring		1
○ 34	410403001	Solenoid cord #3		1	88	409197001	Screw with washer		2
○ 35	410396000	Tube 10×250		1	○ 89	410186001	Timing belt		1
36	408481002	Spacer 4×7		2	○ 90a-c		Power supply board assembly		1
○ 37	410249001	Screw with washer 3×14		2	○ 90b	410337001	Tubular fuse 0.8A		1
○ 38	410243000	Timing belt cover R		1	○ 90c	410475001	Tubular fuse 2A #G		1
39	060670503	+ - Screw 3.57×5		2	91	409197001	Screw with washer		3
40	409197001	Screw with washer		5	○ 92	410442000	Insulation sheet		1
○ 41	410439000	Wire binder	547262001	1	○ 93	410162000	Power supply board holder plate		1
○ 42-76	410251001	Card reader unit		1	94	409621001	+ - Screw 3.18		4
○ 42-50	410268001	Card guide assembly		1	○ 95	410311001	Encoder board assembly		1
○ 42	410252001	Card guide A		1	96	062660503	+ - Screw 3.18×5		3
○ 43	410286001	Sprocket wheel Z10		2	○ 97	410438000	Encoder signal cord cover		1
○ 44	410287001	Card feeding shaft		1	○ 98	547262001	Wire binder		1
45	047211250	Spring pin BW2		2	○ 99	410318001	Left position sensor board assembly		1
46	048040346	Snap ring		1	○ 100	410299000	Encoder signal cord holder		1
○ 47	410291000	Gear Z24 for card feeding dial		1	101	409197001	Screw with washer		1
○ 48	410250000	Spring pin BW1.6		1	102	409197001	Screw with washer		1
○ 49	410297000	Card guide middle		1					
○ 50	004020503	+ Flat head screw 2×5		1	* ○ 90a-d	411010001	Power supply board assembly for UL		1
○ 51a-b	410338001	Mark sensor		1	90b	410337001	Tubular fuse 0.8A		1
○ 51b	410271001	Mark sensor clamp screw		1	90c	125583001	Tubular fuse 2A UL		1
○ 52	410298000	Spacer 3.4×12 square		2	90d	223115000	Lead fuse 5A		1

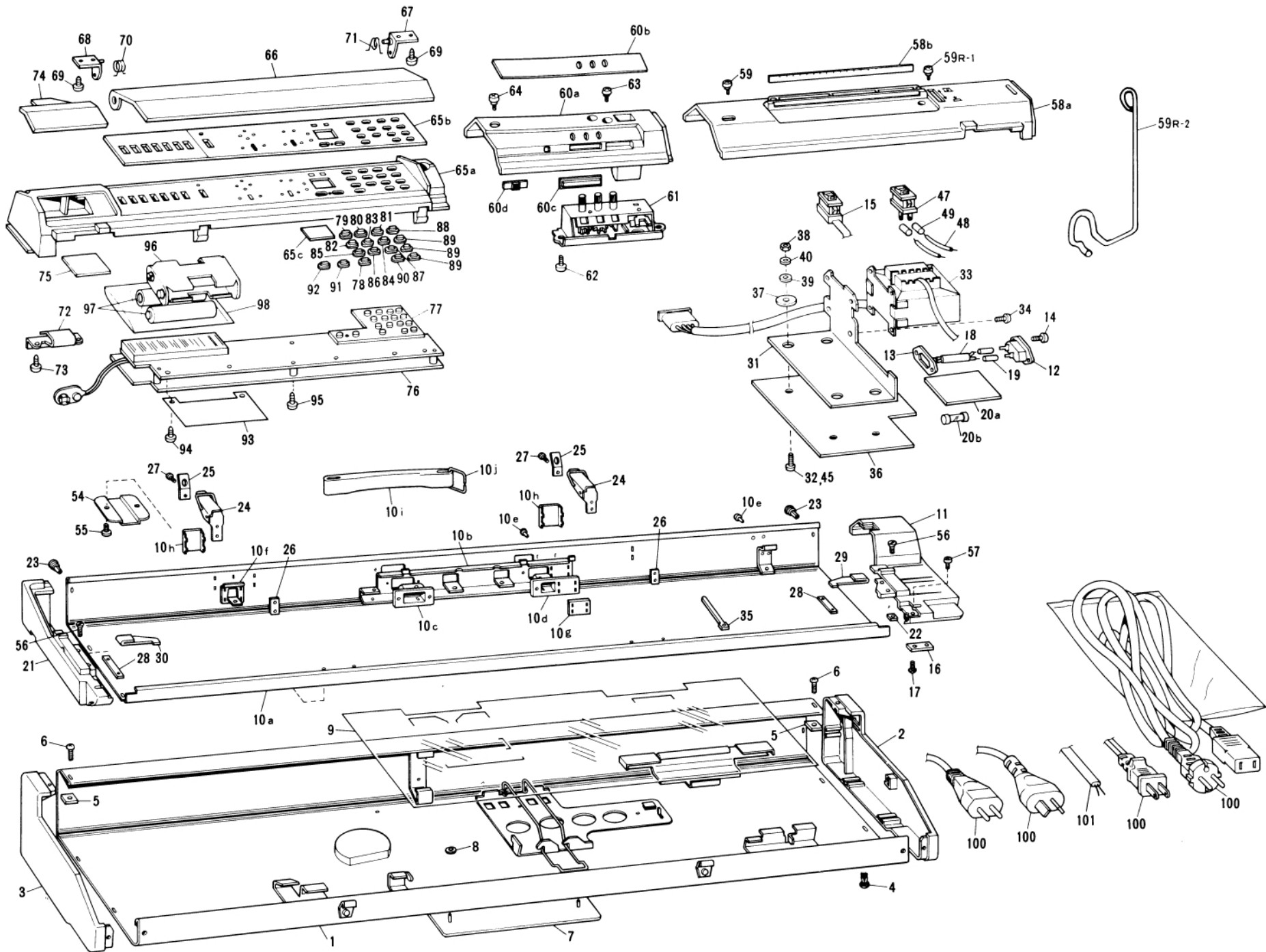

PARTS FOR CARRYING CASE **Fig: D**

PARTS FOR CARRYING CASE

Ref. No.	Parts No.	Description	Revised	Q'ty	Ref. No.	Parts No.	Description	Revised	Q'ty
* D- 1- 9	410812001	Carrying case complete 910A		1	○ D- 65a-95	410865001	Pattern case whole unit #G		1
1	410822001	Carrying case upper assembly 910A		1	○ 65a-c	410805001	Pattern case		1
2	409692001	Carrying case upper body		1	○ 65a-75	410804001	Pattern case assembly		1
3	409693001	Upper side plate right		1	○ 66	410807001	Lid for pattern case		1
4	408194001	Upper side plate left		1	○ 67	410553001	Holder plate R for lid		1
5	407252001	Plastic rivet		8	○ 68	410554001	Holder plate L for lid		1
6	408306001	Screw		2	○ 69	037270613	Tapping screw 1-2.6		4
7	○ 410814001	Brother name plate KH-910		1	○ 70	410549001	Spring L for pattern case lid		1
8	408784001	Pushing nut		2	○ 71	410550001	Spring R for pattern case lid		1
9	○ 410505001	Packing instruction sheet		1	○ 72	410555001	Spring for lid		1
* 10a-j	410509001	Carrying case lower assembly		1	○ 73	037270613	Tapping screw 1-2.6		2
* 11-20b		Carrying case lower body		1	○ 74	410808001	Lid for battery case		1
* 11		Lower side plate, R assembly		1	○ 75	410436001	Battery cord holder		1
* 12		Lower side plate right		1	○ 76	410866001	Main PC board assembly ±G		1
* ○ 13	410306000	AC inlet		1	○ 77	410552001	Conductive rubber plate		1
* ○ 14	000301002	AC inlet clamp		2	○ 78	342892001	Numeral key 0		1
* ○ 15	410892001	+ Screw 3×10		2	○ 79	342883001	Numeral key 1		1
* ○ 16	410891001	Power switch WK2A5 assembly		1	○ 80	342884001	Numeral key 2		1
* ○ 17	037300815	Presser for cord clamp		1	○ 81	342885001	Numeral key 3		1
* ○ 18	410895001	Tapping screw 3×8		2	○ 82	342886001	Numeral key 4		1
* ○ 19	410440000	AC inlet cord		1	○ 83	342887001	Numeral key 5		1
* 20a-b		Insulation sleeve 4×15	410410000	2	○ 84	342888001	Numeral key 6		1
* 20b		Filter board assembly		1	○ 85	342889001	Numeral key 7		1
21	409699001	Tubular fuse		1	○ 86	342890001	Numeral key 8		1
22	409700001	Lower side plate left		2	○ 87	342891001	Numeral key 9		1
23	408194001	Square nut 3.18		2	○ 88	342740005	CE key		1
24	404022001	Plastic rivet		6	○ 89	342740007	Gray key for CF, RR & CR		3
25	404027001	Carrying case lock assembly		2	○ 90	342740004	M key		1
26	403542001	Carrying case lock spring		2	○ 91	342740008	Green key		1
27	405658001	Fastening plate		2	○ 92	342740009	Yellow key		1
28	407265000	Fastening screw		4	○ 93	410434000	Protection sheet for flat cable		1
29	409640001	Needle bed fastening plate		2	○ 94	037270815	Tapping screw 1-26		12
30	409639001	Extension rail lock spring, right		1	○ 95	037270815	Tapping screw 1-26		5
* 31		Extension rail lock spring, left		1	○ 96	410538001	Battery case		1
* ○ 32	410864001	Heat sinker plate		1	○ 97	410421001	Alkaline battery Set (2 pcs.)		1
* 33		Screw 3.18×14		4	○ 98	410616001	Bag for battery		1
* 34	060670603	Power transformer		4	○ 100		Power cord		1
○ 35	547262001	+ - Screw 3.57×6		3	○ 101		Power cord without plug		1
○ 36	410830000	Wire binder		1	* ○ 47	410309001	Power switch WK 2A5 for UL		3
○ 37	410829000	Insulation board		1	○ 48	410400001	Primary cord		2
38	021660103	Insulation spacer		4	○ 49	410410000	Insulation sleeve 4×15		1
39	025660336	Nut		4					
40	028350246	Washer, 3.18		4					
45	408306001	Spring washer		4	(optional)				
54	407261001	Screw		4		487082001	Alkaline Battery Set (2pcs.)		
55	060660604	Table clamp setting plate		4					
56	407119001	+ - Screw 3.18×6		4	59R-1	411448001	Stud screw 3.18		1
57	060660704	Screw		2	59R-2	411449001	Card holder		1
* ○ 58a-b		+ - Screw 3.18×7		2					
○ 59	410535001	Needle selector panel assembly		2					
○ 60a-62	410528002	Stud screw 3.18		1					
○ 61	410531001	Panel and row counter assembly		1					
○ 62	037351015	Row counter assembly		1					
○ 63	410535001	Tapping screw		2					
○ 64	410529001	Stud screw 3.18		1					
		Stud screw 3.18		1					

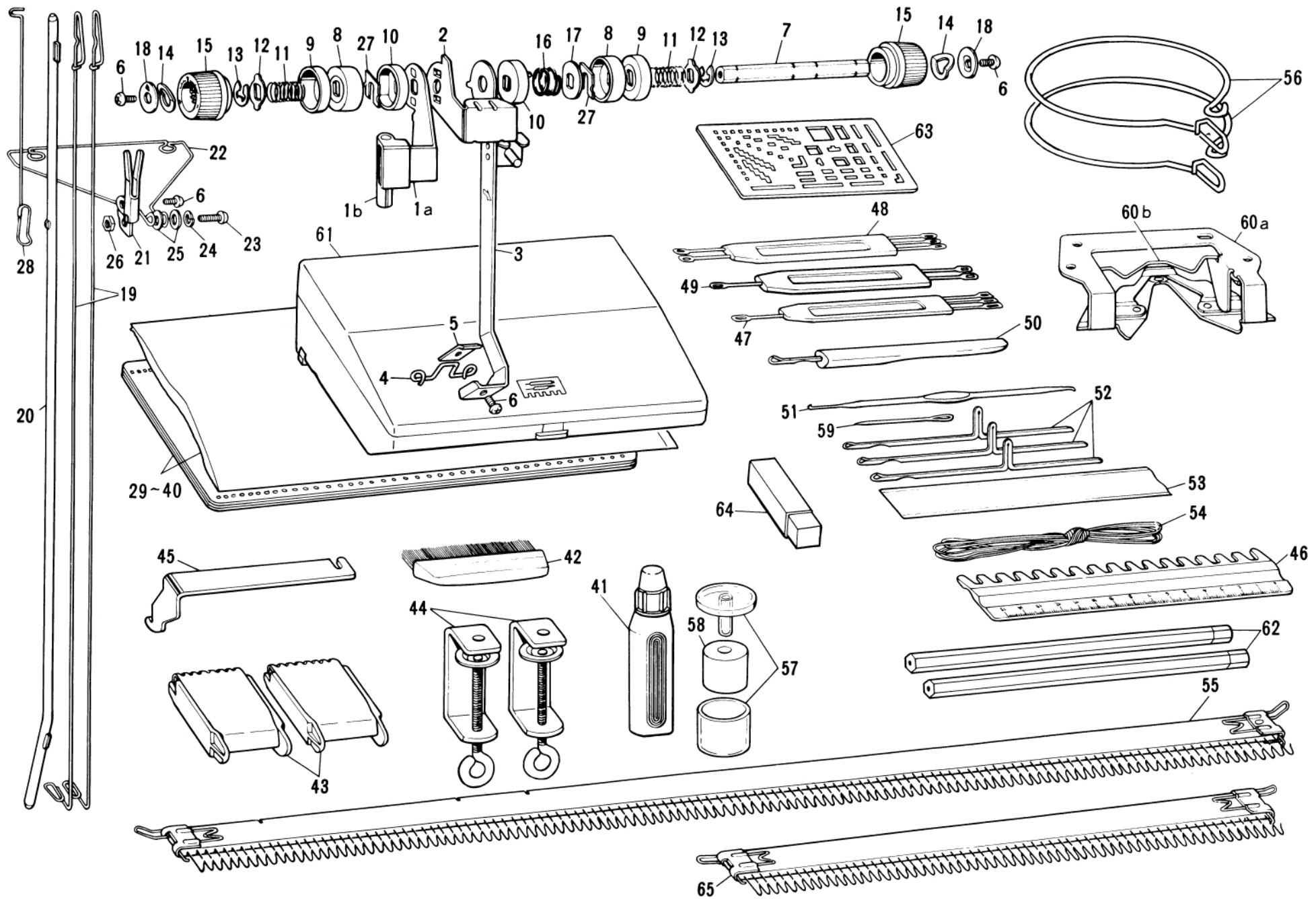

PARTS FOR ACCESSORIES

Fig. E

PARTS FOR ACCESSORIES

Ref. No.	Parts No.	Description	Revised	Q'ty	Ref. No.	Parts No.	Description	Revised	Q'ty
○ E- 1a-28	410863001	Yarn tension unit assembly		1					
19	404755001	Take-up spring		2					
28	408614001	Sub take-up spring		1					
○ 29-40	410600001	Pattern card set		1					
41	405135004	Special knitting machine oil		1					
42	403552002	Hand brush		1					
43	404883005	Claw weight		2					
44	409198001	Table clamp		2					
45	409756001	Carriage lock		1					
46	407482002	1/1 needle pusher		1					
47	402575003	1×3 transfer tool		1					
48	402631003	2×3 transfer tool		1					
49	402576003	1×2 transfer tool		1					
50	407458002	Latch tool		1					
51	402577001	Crochet		1					
52	407113001	Plain needle		3					
53	407483000	Spare needle case		1					
54	402389001	Cast-on thread		1					
55	404787005	Cast-on comb, long		1					
56	410595001	Pattern card guide		2					
57-58	487221001	Yarn wax with case		1					
59	402714001	Tapestry needle		1					
60a-b	409883001	Plating yarn feeder assembly	410971001	1					
61	409752001	Accessories box		1					
○ 62-a	410597001	Special pencil hard		1					
62-b	411115001	Special pencil soft		1					
○ 63	410596001	Template		1					
○ 64	410618001	Eraser		1					
65	404884005	Cast-on comb, short		1					
(Optional)	○ 487067001	Blank cards set for electroknit (5 pcs. in one set)							

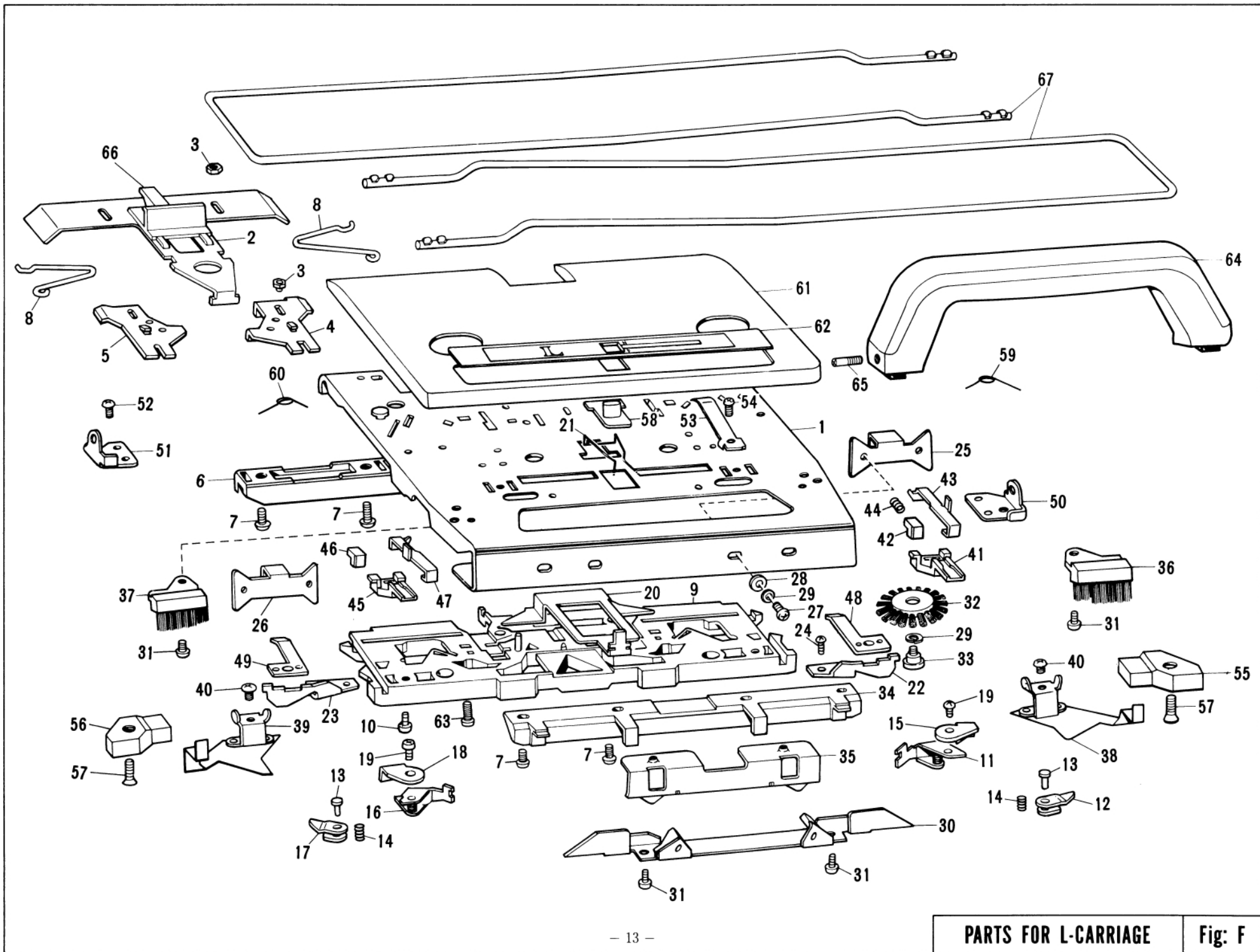

PARTS FOR L-CARRIAGE

Ref. No.	Parts No.	Description	Revised	Q'ty	Ref. No.	Parts No.	Description	Revised	Q'ty
○ F- 1-66	410819001	L carriage assembly KH-910		1	F-57	004661003	Screw		2
○ 1	410481001	L carriage plate		1	58	409744002	Lace selecting knob		1
○ 2	410483001	Release button plate		1	○ 59	410966001	R end needle selection change spring		1
3	408166001	Stud for release button plate		4	○ 60	410967001	L end needle selection change spring		1
○ 4	410484001	Connecting plate R for L carriage		1	○ 61-62	410820001	L carriage cover assembly		1
○ 5	410485001	Connecting plate L for L carriage		1	○ 62	410821001	L carriage cover decoration plate		1
○ 6	410566000	Rear foot for L		1	63	060660403	+ - Screw 3.18×4		2
7	060660703	+ - Screw 3.18×7		8	64	409748001	L carriage handle		1
○ 8	410486001	Connecting plate spring		2	65	409751001	Screw		2
○ 9	410573001	Main cam		1	○ 66	410585001	Release button		1
10	060660703	+ - Screw 3.18×7		2	○ 67	410594001	Extension rail		2
○ 11	410578001	Separation cam R for L carriage		1					
12	408132001	Raising cam right for L carriage		1					
○ 13	410579001	Shaft for separation cam		1					
14	408134001	Raising cam spring		1					
○ 15	410580001	Reinforcing plate BR for main cam		1					
○ 16	410581001	Separation cam L for L carriage		1					
17	408137001	Raising cam left for L carriage		1					
○ 18	410582001	Reinforcing plate BL for main cam		1					
19	060660603	+ - Screw 3.18×6		2					
20	408582001	Lace selecting cam		1					
21	408583001	Change lever spring		1					
○ 22	410583001	Right end needle separation cam for L		1					
○ 23	410584001	Left end needle separation cam for L		1					
○ 24	410592001	+ - Screw 3.18×12		2					
○ 25	410494001	Needle transfer plate R		1					
○ 26	410495001	Needle transfer plate L		1					
27	060660504	+ - Screw 3.18×5		4					
28	403069001	Washer		4					
29	028030243	Spring washer		6					
30	408573001	Cam plate		1					
31	060660403	+ - Screw 3.18×4		4					
32	408146002	Wheel brush		2					
33	405029001	Stud screw		2					
34	407490000	Front foot		1					
35	408579001	Front foot holder		1					
36	408580002	Small brush, right		1					
37	408581002	Small brush, left		1					
38	408561001	Spring plate, right		1					
39	408562001	Spring plate, left		1					
40	060660403	+ - Screw 3.18×4		2					
○ 41	410957001	R end needle selection cam for L		1					
○ 42	410959001	R end needle selection change cam for L		1					
○ 43	410958001	R end needle selection plate for L		1					
○ 44	410963901	End needle selection cam spring for L	410963001	2					
○ 45	410960001	L end needle selection cam for L		1					
○ 46	410962001	L end needle selection change cam for L		1					
○ 47	410961001	L end needle selection plate for L		1					
○ 48	410986001	Right arresting plate for impact		1					
○ 49	410987001	Left arresting plate for impact		1					
50	409740001	Handle setting base, right		1					
51	409739001	Handle setting base, left		1					
52	060670503	+ - Screw 3.57×5		2					
53	407522001	Handle lock spring		2					
54	060660403	+ - Screw 3.18×4		2					
55	407454000	Magnet, right		1					
56	407578000	Magnet, left		1					