

# ***PARTS CATALOGUE FOR KH-900 KNITTING MACHINE***

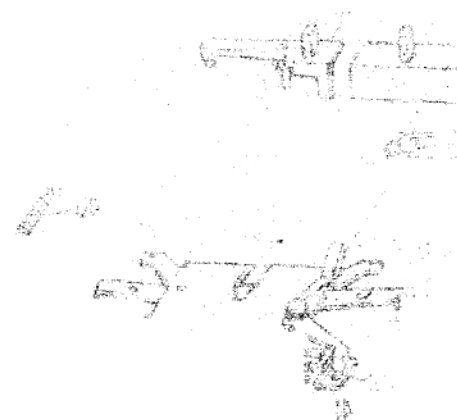

***Parts marked “○” are new for KH-900 and not interchangeable with other models.***

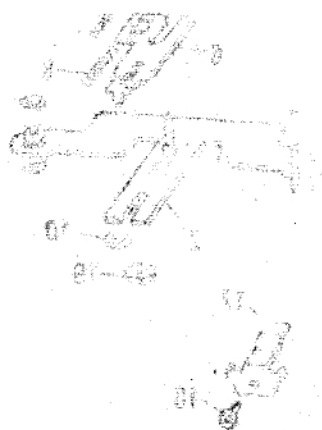
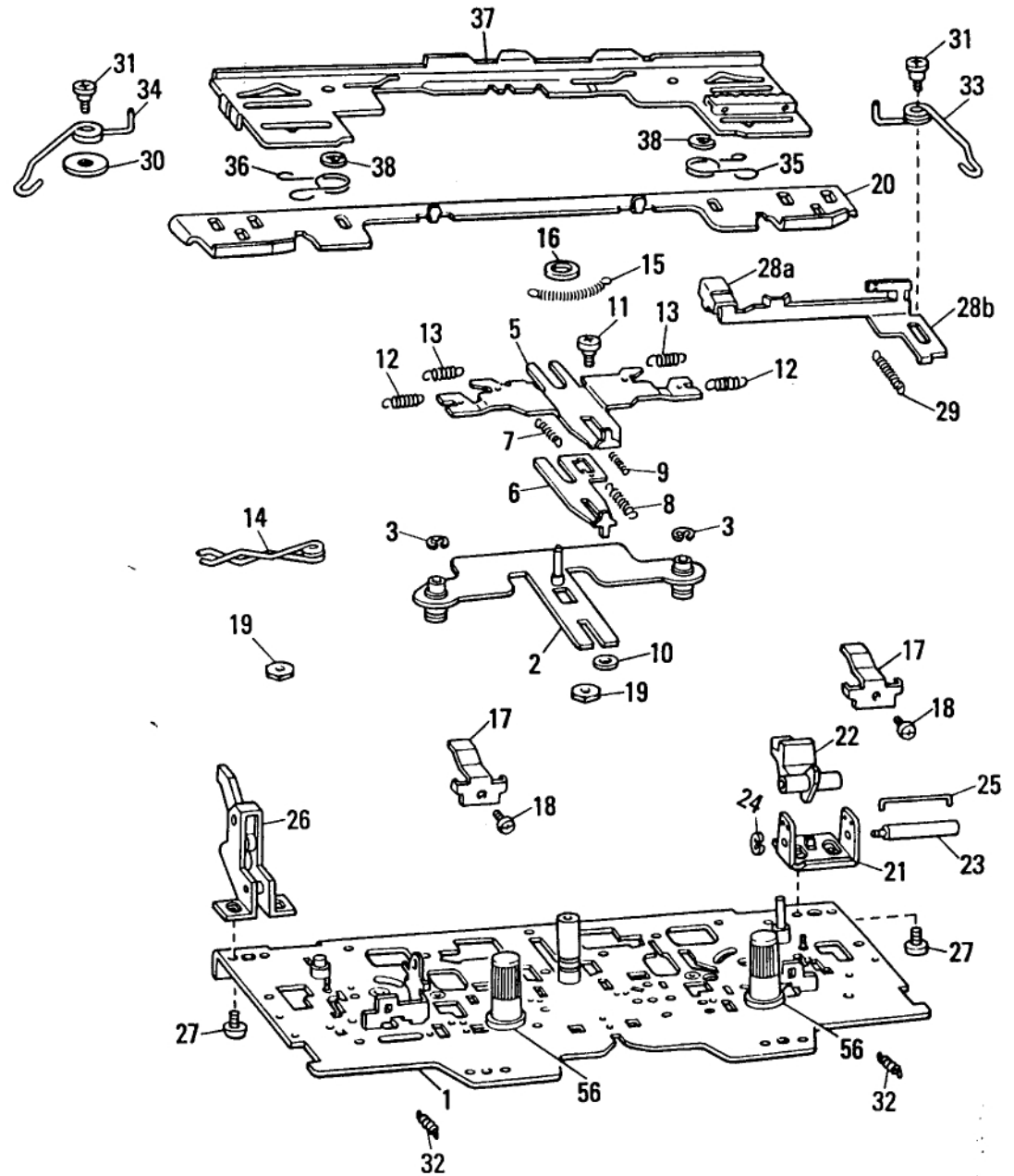
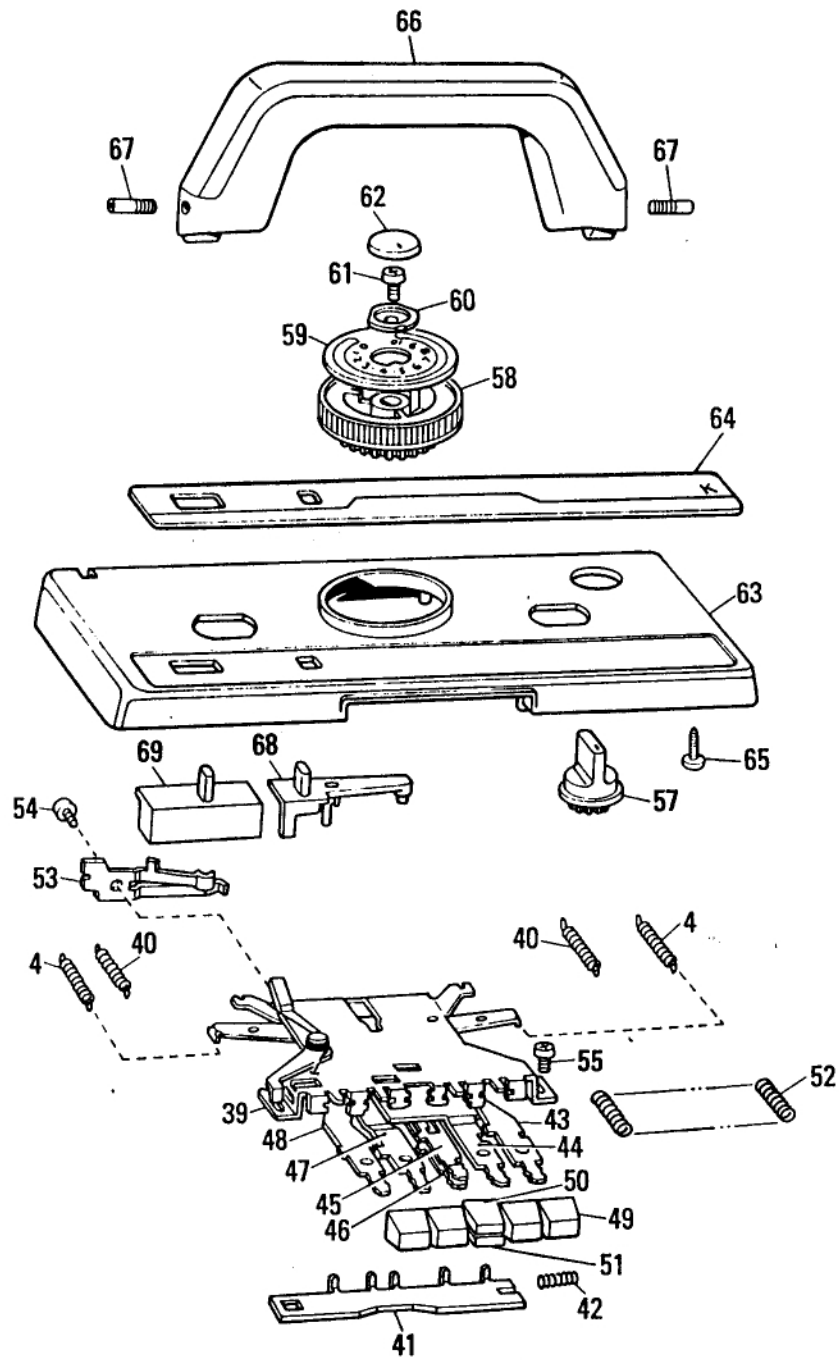

# PARTS FOR CARRIAGE UPPER PART

Ref. No.	Parts No.	Description	Revised	Q'ty	Ref. No.	Parts No.	Description	Revised	Q'ty
○ AI- 1- AII-186	417273001	K carriage complete set KH-900		1	51	413379002	Push button A		1
○ AI- 1	417274001	Carriage plate		1	52	403008001	Push button release spring		4
2	414022001	Stitch cam guide plate		1	53	409595001	Stitch dial stopper spring		1
3	048030346	Snap ring 3		2	54	060660506	+ Screw 3.18 - 40 x 5		1
4	407432001	Raising cam change spring		2	55	060670406	+ Screw 3.57 - 40 x 4		2
5	414053000	Change plate A		1	○ 56	409596003	Thum nut		2
6	414054000	Change plate B		1	○ 57	409597008	Change knob		1
7	414370001	Change plate A spring		1	58	409599003	Stitch dial		1
8	414252001	Change plate B spring		1	59	414174003	Stitch dial indicator plate		1
9	413452001	Change plate spring		1	60	406283001	Stitch dial presser		1
10	414251001	Collar		1	61	060660606	+ Screw 3.18 - 40 x 6		1
11	414025001	Change plate guide collar		1	○ 62	409601007	Stitch dial cap		1
12	414241001	MC cam change spring		2	○ 63-64	417277001	K carriage cover assembly KH-900		1
13	414178001	MC cam spring A		2	○ 63	417278001	K carriage cover		1
14	407333001	H.C.L. spring		1	○ 64	417279001	Carriage cover decoration plate for KH-900		1
15	414069001	Tuck cam spring		1	65	037351615	Screw 3.5 x 16		2
16	414180001	Presser ring		1	66	409605007	K carriage handle		1
17	414084001	Handle lock spring		2	67	409608001	Screw		2
18	062670406	Screw 3.57 - 40 x 4		2	68	413437001	Plain lever knob		1
19	021670306	Nut 3.57 - 40		2	○ 69	417293001	H.C.L. knob		1
20	409554001	Rear plate		1					
○ 21-25	410130001	Row counter tripper		1					
26	410132101	Knit leader tripper		1					
27	060660406	+ Screw 3.18 - 40 x 4		4					
28	410141003	K carriage sensor magnet assembly		1					
29	412131001	Shift spring for K carriage sensor		1					
30	025050335	Washer		1					
31	410146001	Shaft for K carriage sensor magnet		2					
32	410135001	End needle selection cam spring		2					
33	414189001	Needle selection change spring, R		1					
34	414190001	Needle selection change spring, L		1					
35	409543001	Connecting plate spring, R		1					
36	409544001	Connecting plate spring, L		1					
○ 37	417275001	Upper slide plate		1					
38	048040346	Snap ring 4		2					
39-54	414113001	Cam button unit		1					
39	414114001	Cam button unit body		1					
40	407512001	Raising cam spring		2					
41	413545001	Stopper plate		1					
42	405524001	Stopper spring		1					
43	414118001	Part plate, R		1					
44	414119001	Part plate, L		1					
45	413377001	MC plate		1					
46	413378001	L plate		1					
47	414116001	Tuck plate, R		1					
48	414117001	Tuck plate, L		1					
49	405302007	Push button		4					
50	414181001	Push button B		1					

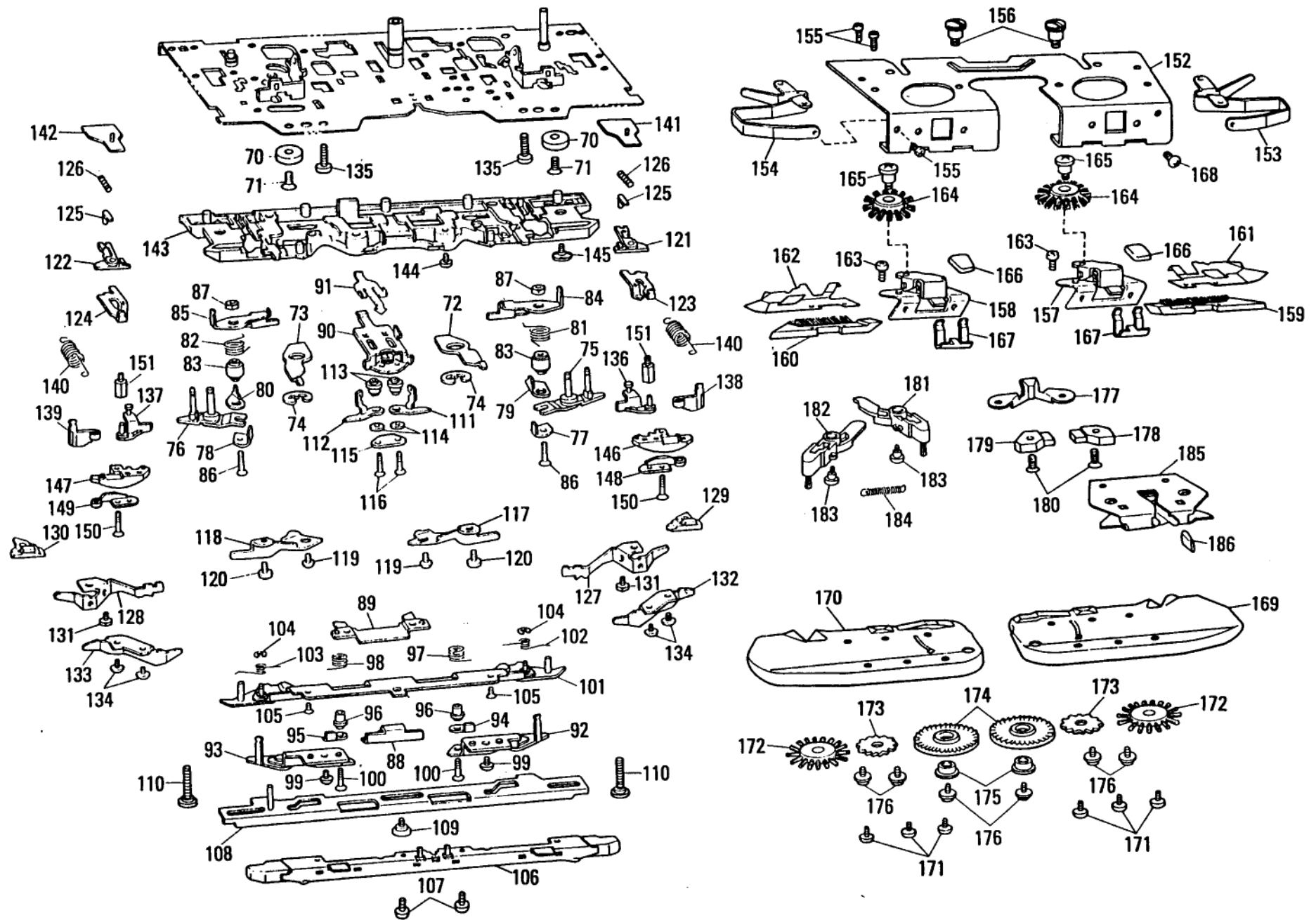

## PARTS FOR CARRIAGE LOWER PART

Ref. No.	Parts No.	Description	Revised	Q'ty	Ref. No.	Parts No.	Description	Revised	Q'ty
All- 70	407285000	Carriage magnet 16 x 8		2	119	414049001	Screw		2
71	408773006	Flat head screw 3.18 - 40 x 9		2	120	413554001	Screw 3.18 x 3		2
72	414242001	Raising cam guide, R		1	121	410922002	Selection cam for right end needle		1
73	414243001	Raising cam guide, L		1	122	410923002	Selection cam for left end needle		1
74	048070346	Snap ring 7		2	123	410924101	Selection guide for right end needle		1
75	414026001	Stitch cam assembly, R		1	124	410925101	Selection guide for left end needle		1
76	414030001	Stitch cam assembly, L		1	125	410926001	End needle selection switch cam		2
77	407296001	Sub stitch cam, R		1	126	412215001	End needle selection cam spring		2
78	407297001	Sub stitch cam, L		1	127	414487001	Separation cam, right		1
79	410488001	Valve cam D, R		1	128	414488001	Separation cam, left		1
80	410489001	Valve cam D, L		1	129	410929000	Buffer right for selected needle		1
81	410490001	Valve cam D spring, R		1	130	410930000	Buffer left for selected needle		1
82	410491001	Valve cam D spring, L		1	131	060660406	+ Screw 3.18 - 40 x 4		2
83	414245001	Sub stitch cam shaft		2	132	414082001	Guide cam F, R		1
84	414032001	MC cam, R		1	133	414083001	Guide cam F, L		1
85	414033001	MC cam, L		1	134	413554001	Screw 3.18 x 3		4
86	407312001	Screw		2	135	062681206	Screw 4.37 - 40 x 12		2
87	021660306	Nut 3.18 - 40		2	136	414185001	Needle selection change cam, R		1
88	414034001	Slide cam		1	137	414187001	Needle selection change cam, L		1
89	414035001	Slide cam guide		1	138	414203001	Valve cam F, R		1
90	414036001	Guide cam C		1	139	414204001	Valve cam F, L		1
91	414462000	Guide cam C spring		1	140	409570001	Valve cam F spring		2
92	414041001	Guide cam B, R		1	141	409539001	Connecting plate, R		1
93	414045001	Guide cam B, L		1	142	409541001	Connecting plate, L		1
94	414176001	Valve cam B, R		1	143	414086001	Rear foot		1
95	414177001	Valve cam B, L		1	144	060660406	+ Screw 3.18 - 40 x 4		4
96	414050001	Valve cam B shaft		2	145	409494001	Screw 3.57		2
97	414051001	Valve cam B spring, R		1	146	417167001	Selection cam, R		1
98	414052001	Valve cam B spring, L		1	147	417168001	Selection cam, L		1
99	413554001	Screw 3.18 x 3		2	148	409537001	Guide cam G, R		1
100	407299001	Screw		2	149	409538001	Guide cam G, L		1
101-104	414055001	Guide cam A assembly		1	150	410030001	Screw 2.38 x 14		2
101	414056001	Guide cam A		1	151	414091001	Selection change cam shaft		2
102	414194001	Change cam spring, R		1	152-186	415551001	Sinker plate assembly		1
103	414195001	Change cam spring, L		1	152-176	415552001	Sinker plate arm assembly		1
104	048025346	Snap ring 2.5		2	152	409979001	Sinker plate arm		1
105	413285001	Screw 3.18 x 4		2	153	414122000	Weaving thread guide, R		1
106	414172001	Front foot		1	154	414123000	Weaving thread guide, L		1
107	413554001	Screw 3.18 x 3		2	155	409162001	Tapping screw 2.6		6
108	414062001	Front slide plate		1	156	409626001	Thumb screw		2
109	414184001	Screw 3.18 x 4		1	157	410026001	Weaving lever assembly, R		1
110	408504001	Screw 3.18		2	158	410027001	Weaving lever assembly, L		1
111	414066001	Tuck cam, R		1	159	410003001	Latch opening brush, R		1
112	414067001	Tuck cam, L		1	160	410004001	Latch opening brush, L		1
113	414068001	Tuck cam shaft		2	161	414191000	Latch presser plate, R		1
114	414179001	Washer		2	162	414192000	Latch presser plate, L		1
115	407340001	Tuck cam plate		1	163	037280616	Tapping screw 2.6 x 6		4
116	407299001	Screw		2	164	414417001	Weaving pattern brush		2
○ 117	417486001	Guide cam D, R		1	165	408316001	Screw 3.18		2
○ 118	417487001	Guide cam D, L		1	166	409629003	Weaving lever knob		2

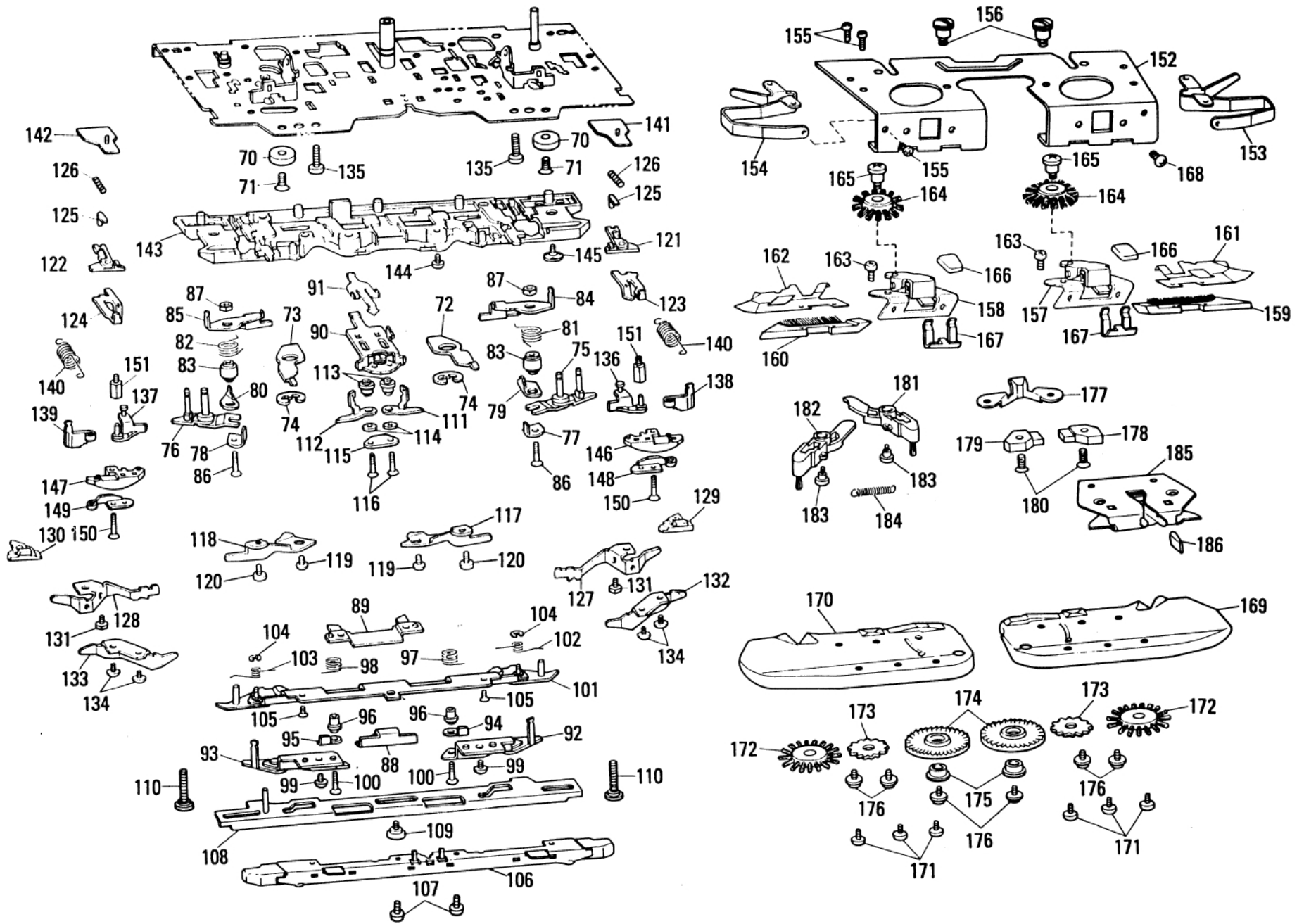

## PARTS FOR CARRIAGE LOWER PART

Ref. No.	Parts No.	Description	Revised	Q'ty	Ref. No.	Parts No.	Description	Revised	Q'ty
167	407441001	Weaving lever spring		2					
168	408305001	Screw 3.18 × 5		4					
169	409614001	Sinker plate, R		1					
170	409618001	Sinker plate, L		1					
171	412049006	← Screw 3.18 – 40 × 3.5		6					
172	407702001	Wheel brush		2					
173	405184002	Plastic gear		2					
174	413403001	Rubber wheel		2					
175	410970001	Holder		2					
176	409621001	Screw 3.18 × 4		6					
177-186	414129001	Double yarn feeder assembly		1					
177	409625000	Magnet holder plate		1					
178	407454000	Magnet, R		1					
179	407578000	Magnet, L		1					
180	413247001	Screw 2.38 × 10		2					
181	414196001	Yarn presser brush, R		1					
182	414197001	Yarn presser brush, L		1					
183	414249001	Screw		2					
184	414250001	Spring		1					
185	414130001	Yarn feeder body		1					
186	407450004	Yarn feeder knob		1					

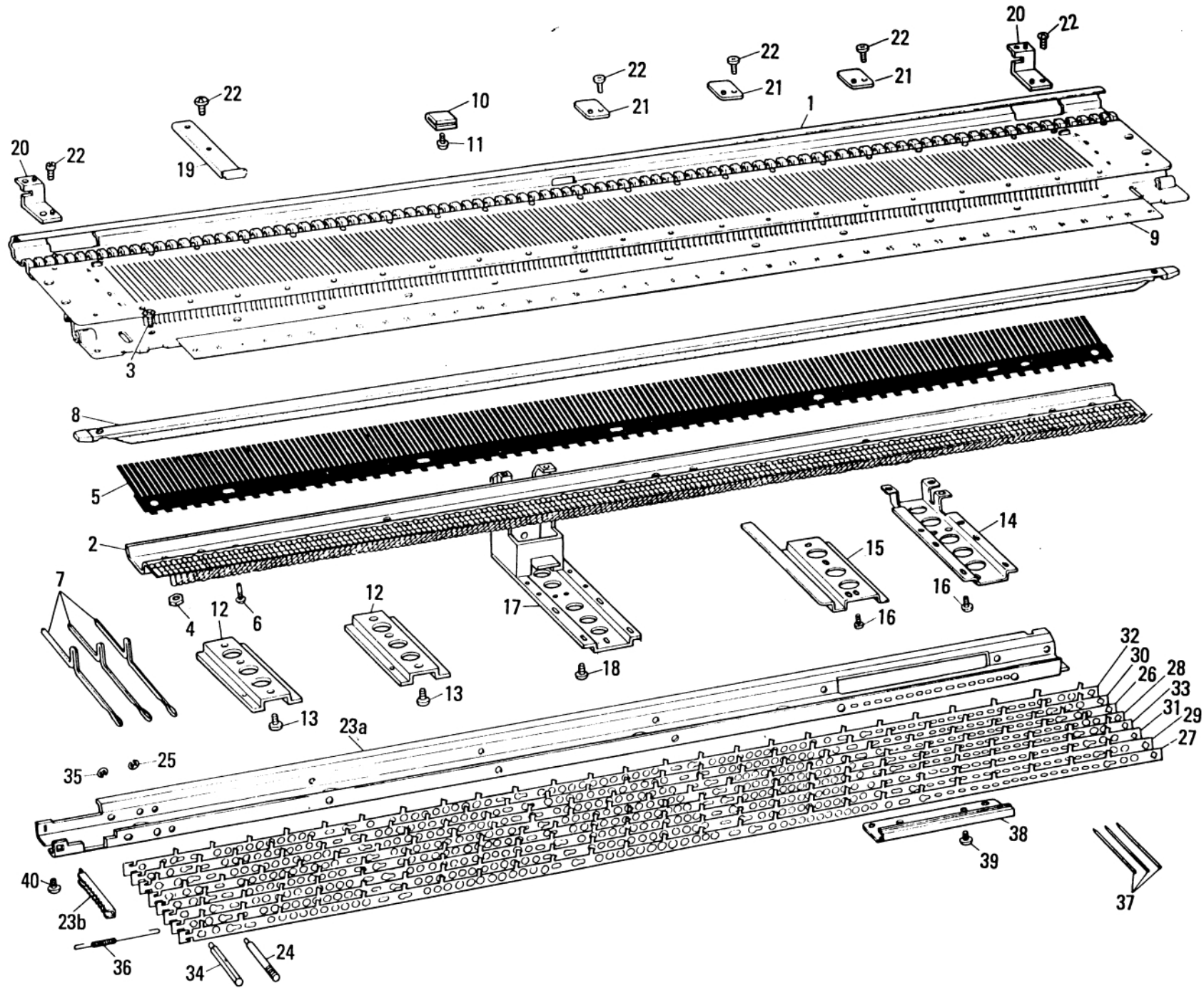

PARTS FOR NEEDLE BED Fig: B



## PARTS FOR NEEDLE BED

Ref. No.	Parts No.	Description	Revised	Q'ty	Ref. No.	Parts No.	Description	Revised	Q'ty
○ B-	1	412803101		1					
○	2	410154101		1					
	3	412109004		12					
	4	405077001		12					
	5	407112001		1					
	6	407687001		3					
	7	407113001		200					
	8	409643003		1					
	9	410157001		1					
	10	409656000		1					
	11	412048006		1					
	12	407120000		2					
	13	409197001		4					
	14	410159000		1					
	15	408061000		1					
	16	409197001		6					
○	17	410161101		1					
	18	409197001		4					
	19	410170000		1					
	20	410175000		2					
	21	413952000		3					
	22	410523001		6					
○	23-36	410188101		1					
○	23a-b	487374101		1					
	24	408159001		6					
	25	048025346		6					
	26	410191001		1					
	27	410192001		1					
	28	410193001		1					
	29	410194001		1					
	30	410195001		1					
	31	410196001		1					
	32	410197001		1					
	33	410198001		1					
	34	408172001		1					
	35	048025346		1					
	36	410476001		8					
	37	408098001		16					
	38	410199001		1					
	39	409197001		2					
	40	409197001		7					

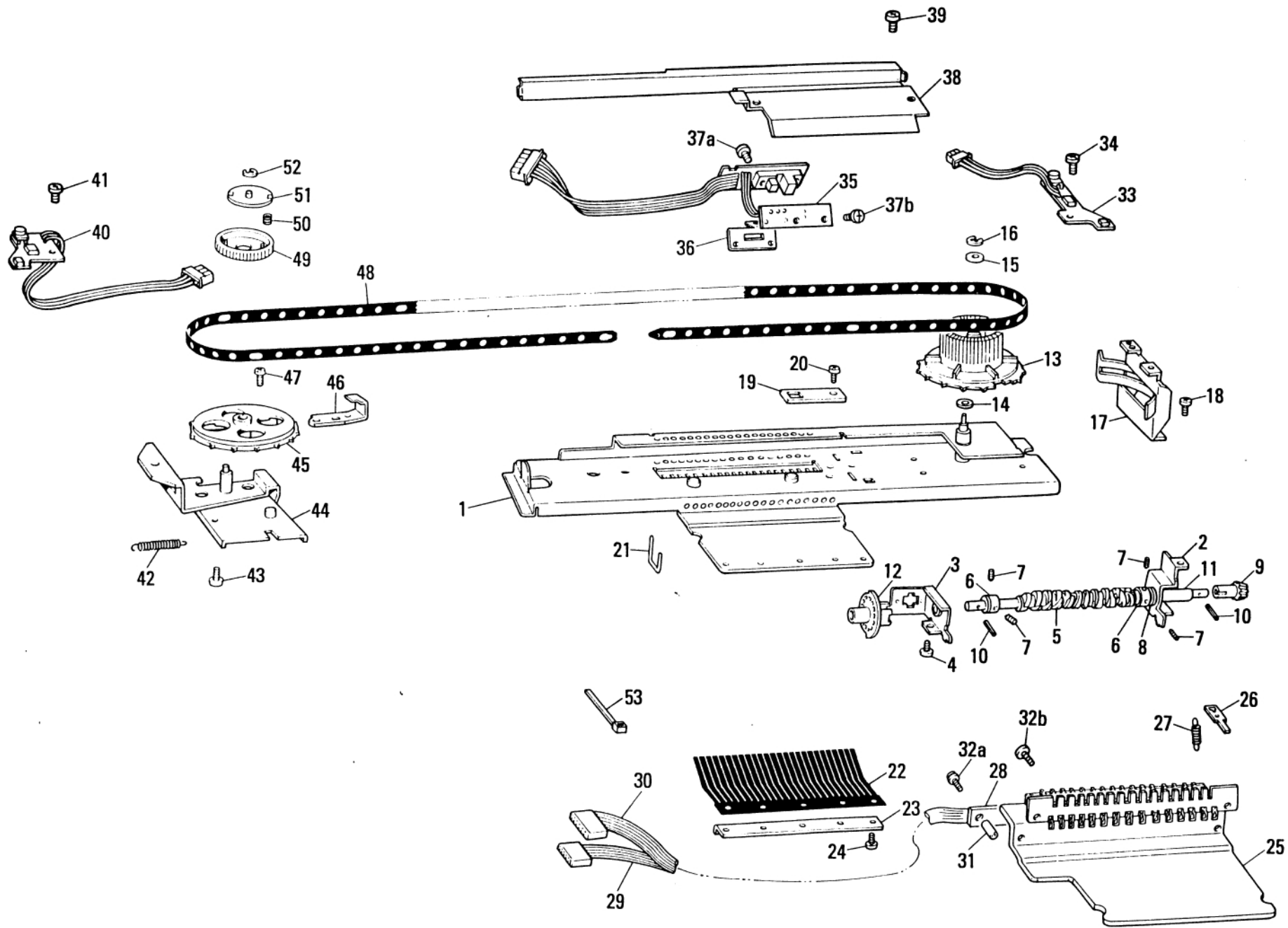

PARTS FOR NEEDLE SELECTOR UNIT Fig. C

## PARTS FOR NEEDLE SELECTOR UNIT

Ref. No.	Parts No.	Description	Revised	Q'ty	Ref. No.	Parts No.	Description	Revised	Q'ty
○ C- 1-32	417280001	Rotary cam holder body assembly		1	45	410182002	Pulley		1
○ 1	417281001	Rotary cam holder body		1	46	412034000	Pulley adjusting plate		1
○ 2	417283001	Rotary cam holder, R		1	47	406397001	Screw with washer 3.18 × 5		2
○ 3	417285001	Rotary cam holder, L		1	48	410186001	Timing belt		1
4	409197001	Screw with washer		2	49	410477001	Friction plate		1
○ 5	417397001	Rotary cam		1	50	410479001	Friction plate spring		4
6	410215001	Rotary cam adjuster collar		2	51	410478000	Presser for friction plate spring		1
7	013680516	Stopper screw		4	52	048030346	Snap ring 3		1
8	411013001	Washer 6.3		1					
9	410216000	Bevel gear Z12		1					
10	047201042	Spring pin AW2		2					
11	410217001	Spacer 6.2 × 19		1					
12	413910001	Slit disc		1					
13	410219001	Rotary encoder assembly		1					
14	410223001	Washer 6.3		1					
15	400806004	Washer 3.6		1					
16	048025346	Snap ring 2.5		1					
17	410224000	Encoder board holder		1					
18	409197001	Screw with washer		2					
19	408068001	Card reader guide stopper		1					
20	060660406	+ Screw 3.18 - 40 × 4		1					
21	417287001	Rotary cam lever		16					
22	410226001	Rotary cam lever spring		1					
23	410227000	Cam lever spring presser plate		1					
24	060660406	+ Screw 3.18 - 40 × 4		5					
○ 25-32	417288001	Needle selector solenoid assembly		1					
○ 25	417289001	Solenoid yoke 4.5		1					
○ 26	417291001	Armature		16					
○ 27	417471001	Spring for armature		16					
28	410327001	Solenoid board		1					
○ 29	417298001	Solenoid cord 1		1					
○ 30	417299001	Solenoid cord 2		1					
31	408481002	Spacer 4 × 7		2					
32a	415616001	Screw with washer 3 × 14		2					
32b	060670506	+ Screw 3.57 - 40 × 5		2					
○ 33	417300001	Right position sensor board assembly		1					
34	060660406	+ Screw 3.18 - 40 × 4		2					
○ 35	417031001	Encoder sensor assembly		1					
○ 36	417498000	Encoder board holder plate		1					
37a	062660806	Screw 3.18 - 40 × 8		2					
37b	062660506	Screw 3.18 - 40 × 5		2					
○ 38	417292000	Cored cover		1					
39	060660406	+ Screw 3.18 - 40 × 4		2					
○ 40	417035001	Left position sensor board assembly		1					
41	060660406	+ Screw 3.18 - 40 × 4		1					
42-47	410181002	Pulley assembly		1					
49-52									
42	410016001	Belt tension control spring		1					
43	409197001	Screw with washer		2					
44	410180001	Pulley holder plate		1					

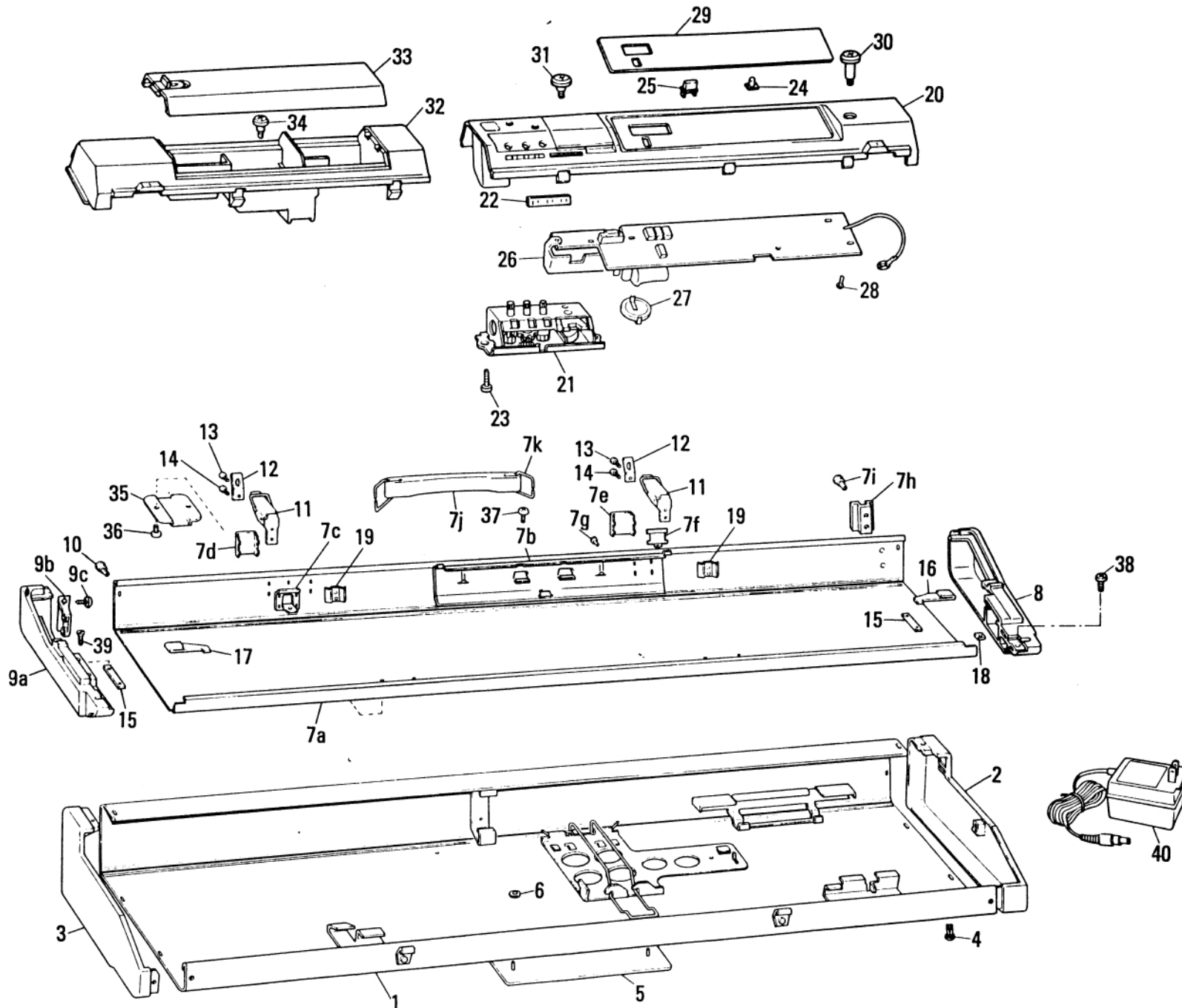

PARTS FOR CARRYING CASE

Fig: D

# PARTS FOR CARRYING CASE 1

Ref. No.	Parts No.	Description	Revised	Q'ty	Ref. No.	Parts No.	Description	Revised	Q'ty
○ D-	1-19	417302001		1	40	415916001	AC Adapter for Knitting Machine (230V, for NZ)		1
○	1-6	417303001		1	40	416225001	AC Adapter for Knitting Machine (220V, for France)		1
○	1	417307001		1	40	416066001	AC Adapter for Knitting Machine (120V, for KK)		1
	2	409692003		1	40	415663001	AC Adapter for Knitting Machine (120V, for CSA)		1
	3	409693003		1	40	416454001	AC Adapter for Knitting Machine (220V)		1
	4	408194003		10					
○	5	417305001		1					
	6	408784001		2					
○	7-19	417306001		1					
○	7a-7k	417308001		1					
	8	409698003		1					
	9a	409699003		1					
	9b	414005001		1					
	9c	037281216		4					
	10	408194003		6					
	11	404022002		2					
	12	404027001		2					
	13	405658001		2					
	14	405658001		2					
	15	407265001		2					
	16	409640001		1					
	17	409639001		1					
	18	409700001		2					
	19	407115000		2					
○	20-29	417527001		1					
○	20-23	417312001		1					
○	20	417691001		1					
	21	410531003		1					
	22	409721003		1					
	23	037351016		2					
○	24	416623002		9					
○	25	417333001		11					
○	26	417317001		1					
○	27	417524001		1					
	28	037280816		8					
○	29	417316001		1					
	30	413946001		1					
	31	410535001		1					
○	32-33	413947101		1					
○	32	413948101		1					
	33	413949001		1					
	34	410535001		1					
	35	407261001		2					
	36	060660704		4					
	37	060660406		3					
	38	060660704		2					
	39	407119001		4					
	40	415665001		1					
	40	415655001		1					
	40	415664001		1					

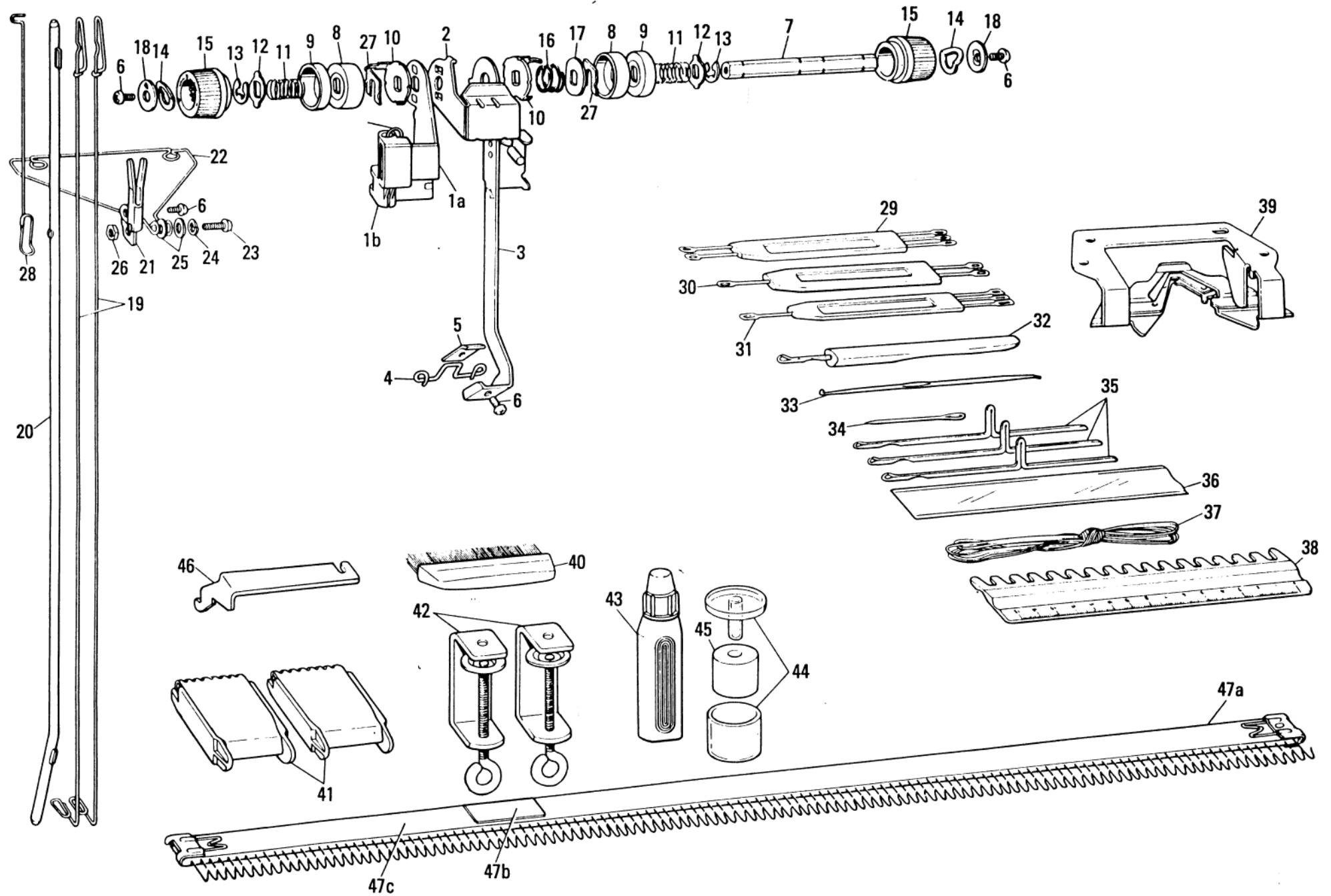

## PARTS FOR ACCESSORIES

Ref. No.	Parts No.	Description	Revised	Q'ty	Ref. No.	Parts No.	Description	Revised	Q'ty
E- 1-28	412183002	Yarn tension unit assembly		1					
19	404755001	Take-up spring		2					
28	408614001	Sub take-up spring		1					
29	402631005	2 × 3 Transfer tool		1					
30	402576005	1 × 2 Transfer tool		1					
31	402575005	1 × 3 Transfer tool		1					
32	407458004	Latch tool		1					
33	414979001	Crochet		1					
34	402714001	Tapestry needle		1					
35	407113001	Plain needle		3					
36	407483000	Spare needle case		1					
37	402389001	Cast-on thread		1					
38	407482004	1/1 Needle pusher		1					
39	410971001	Plating yarn feeder assembly		1					
40	403552004	Hand brush		1					
41	404883006	Claw weight		2					
42	409198001	Table clamp		2					
43	405135004	Knitting machine oil		1					
44-45	487221001	Yarn wax with case		1					
46	407481001	Carriage lock		1					
47a-47c	412878001	Cast-on comb assembly		1					
47a	412879001	Cast-on comb long		1					
47b	411365000	Connecting plate		1					
47c	412881001	Cast-on comb, short		1					

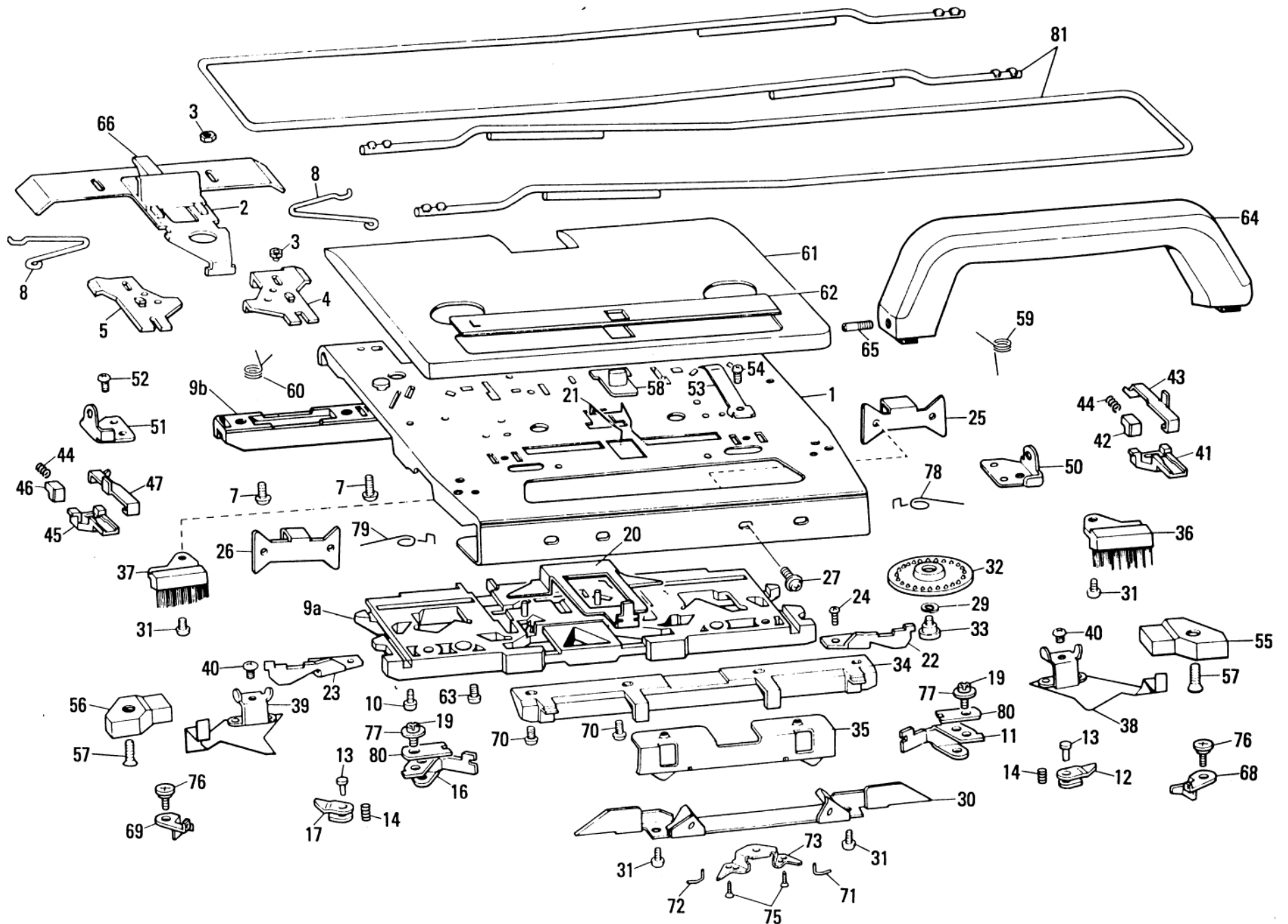



## PARTS FOR L-CARRIAGE (OPTION)

Ref. No.	Parts No.	Description	Revised	Q'ty	Ref. No.	Parts No.	Description	Revised	Q'ty
○ F- 1-80	417621001	L carriage assembly KH-900		1	55	407454000	Magnet, R		1
1	410481001	L carriage plate		1	56	407578000	Magnet, L		1
2	410483001	Release button plate		1	57	417596001	Screw 3.18 – 40 × 10		2
3	408166001	Stud for release button plate		4	58	409744005	Lace selecting knob		1
4	410484001	Connecting plate R for L carriage		1	59	412148001	L valve cam C spring, R		1
5	410485001	Connecting plate L for L carriage		1	60	412147001	L valve cam C spring, L		1
7	060660706	Screw 3.18 – 40 × 7		4	○ 61-62	417496001	L carriage cover		1
8	410486001	Connecting plate spring		2	○ 62	417497001	L carriage cover decoration plate		1
9a	415702001	Main cam		1	63	060660406	Screw 3.18 – 40 × 4		2
9b	415704000	Rear foot		1	64	409748007	L carriage handle		1
10	060660806	Screw 3.18 – 40 × 8		2	65	409751001	Screw		2
11	410578001	Separation cam R for L carriage		1	66	410585005	Release button		1
12	408132001	Raising cam right for L carriage		1	68	412145001	L valve cam C, R		1
13	410579001	Shaft for separation cam		1	69	412146001	L valve cam C, L		1
14	408134001	Raising cam spring		2	70	060660806	Screw 3.18 – 40 × 8		4
16	410581001	Separation cam L for L carriage		1	71	412141001	L valve cam B, R		1
17	408137001	Raising cam left for L carriage		1	72	412142001	L valve cam B, L		1
19	060660706	Screw 3.18 – 40 × 7		2	73	412143001	Reinforcing Plate B		1
20	408582001	Lace selecting cam		1	75	040210812	Screw 2 × 8		2
21	408583001	Change lever spring		1	76	409528001	Lever shaft		2
22	410583001	Right end needle separation cam for L		1	77	403069001	Washer 3.3		2
23	410584001	Left end needle separation cam for L		1	78	410966001	R end needle selection change spring		1
24	410592001	+ Screw 3.18 × 11.6		2	79	410967001	L end needle selection change spring		1
25	410494001	Needle transfer plate R		1	80	412898000	Separation cam plate		2
26	410495001	Needle transfer plate L		1	81	412205002	Extension rail		2
27	413734001	Screw 3.18 – 40 × 4		4					
29	028030243	Spring washer		2					
30	408573001	Cam plate		1					
31	060660406	Screw 3.18 – 40 × 4		4					
32	411003001	Wheel brush		2					
33	405029001	Stud Screw		2					
34	407490000	Front foot		1					
35	408579000	Front foot holder		1					
36	408580004	Small brush, R		1					
37	408581004	Small brush, L		1					
38	408561001	Spring plate, R		1					
39	408562001	Spring plate, L		1					
40	060660406	Screw 3.18 – 40 × 4		2					
41	410957002	R end needle selection cam for L		1					
42	410959001	R end needle selection change cam for L		1					
43	410958001	R end needle selection plate for L		1					
44	410963001	End needle selection cam spring for L		2					
45	410960002	L end needle selection cam for L		1					
46	410962001	L end needle selection change cam for L		1					
47	410961001	L end needle selection plate for L		1					
50	409740001	Handle setting base, R		1					
51	409739001	Handle setting base, L		1					
52	060670506	Screw 3.57 – 40 × 5		2					
53	407522001	Handle lock spring		2					
54	060660406	Screw 3.57 – 40 × 4		2					

**\* Mounting dimension of the Main cam**

Mount the Main cam (Ref. No. F-9a) or Main cam and the Rear foot (Ref. No. F-9b) on the L carriage plate so that the dimension  $\textcircled{A}$  (between both inner faces of cam) are within range of  $45.2\text{m/m} \pm 0.1\text{m/m}$ , according to the following steps. (refer to Fig. 1)

- (1) Tighten the Rear foot with 4 screws, while pushing it toward the "arrow" direction. (Also in case of replacing Rear foot.)
- (2) If you made the adjustment tool as shown in Fig. 1, you can adjust the dimension  $\textcircled{A}$  easily.

And place the adjustment tool between the rear foot and the Main cam, then tighten the Main cam with two screws, while pushing it toward the "arrow" direction.

\* Although you will not use the adjustment tool, you can adjust the dimension  $\textcircled{A}$  with a calipers, the way of adjustment is that put the calipers on the place of dimension  $\textcircled{A}$  then tighten the main cam with two screws, while pushing it toward the "arrow" direction.

- (3) Attach the end needle separation cams  $\textcircled{D}$  while pushing them toward the "arrow" direction.

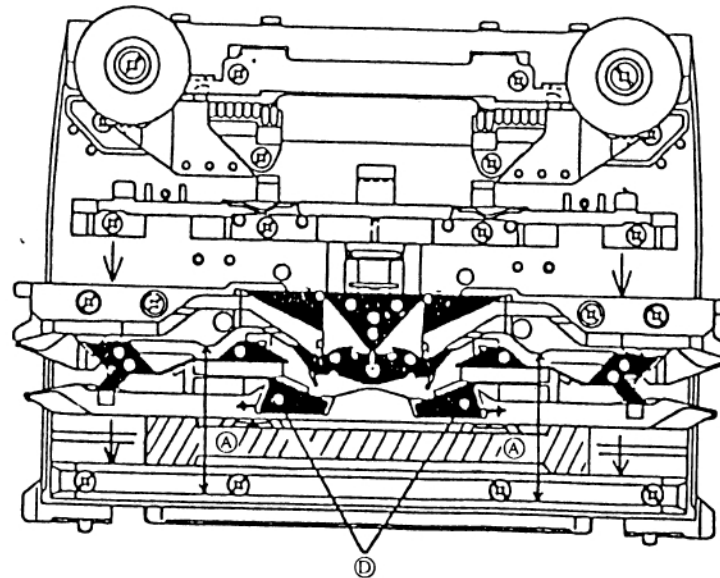
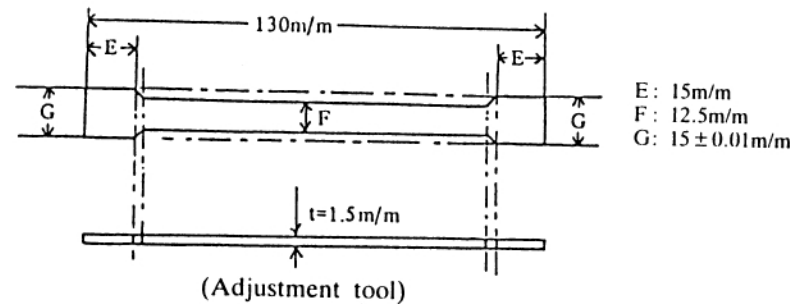

**Fig. 1**